

TRIUMPH

REPLACEMENT PARTS CATALOGUE No. 8

"C" RANGE MODELS

TIGER 90 (T90)

TIGER 100 (T100S, T100R, T100C & T100T)

from Engine No. H 49833

September 1966

TRIUMPH ENGINEERING COMPANY LIMITED
MERIDEN WORKS · ALLESLEY · COVENTRY · ENGLAND
TELEPHONE MERIDEN 331 TELEGRAMS "TRUSTY COVENTRY"

TRIUMPH GUARANTEE

1. In this Guarantee the word "machine" refers to the motor cycle, scooter, motor-cycle combination or sidecar as the case may be, purchased by the Purchaser.
2. In order to obtain the benefit of this Guarantee, the Purchaser must have correctly completed the registration form and returned it to us within fourteen days of the purchase.
3. We will supply, free of charge, a new part in exchange for, or, if we consider repair sufficient, will repair free of charge any part proved within six months of the date of purchase of any new machine, (3 months overseas) or within three months of its renewal or repair in the case of a part already renewed or repaired, to be defective by reason of our faulty workmanship or materials. We do not undertake to bear the cost of fitting such new or repaired part or accessory.
4. Any part considered to be defective must be sent to our Works, carriage paid, accompanied by the following information:—
 - (a) Name of purchaser and his address;
 - (b) Date of purchase of machine;
 - (c) Name of dealer from whom the purchase was made;
 - (d) Engine number and model
5. This Guarantee shall not extend to defect or damage appearing after misuse, neglect, abnormal stress or strain, or the incorporation or affixing of unsuitable attachments or parts and in particular:—
 - (a) Hiring out;
 - (b) Racing and Competitions;
 - (c) Adaptation or alteration of any part or parts after leaving our Works;
 - (d) The attaching of a sidecar in a manner not approved by us or to an unsuitable motor-cycle.

This Guarantee shall not extend to machines whose trade mark, name or manufacturing number has been altered or removed, or in which has been used any part not supplied or approved by us, or to tyres, saddles, chains, speedometers, revolution counters and electrical equipment or to parts supplied to the order of the Purchaser and different from our standard specification.

6. Our liability and that of our dealer who sells the machine, shall be limited to that set out in this guarantee, and no other claims for consequential damage or injury to person or property, shall be admissible. All other conditions and warranties statutory or otherwise and whether express or implied are hereby excluded and no guarantee other than that expressly herein contained applies to the machine to which this Guarantee relates or any accessory or part thereof.
7. We reserve the right to modify or deviate from the Published Specification without notice.

REPAIRS GUARANTEE

1. Whilst the highest standard of workmanship and materials is aimed at, we cannot accept liability for any defects appearing more than three months after the machine, assembly or component has left our Works after being repaired.
2. We will repair or replace at our option free of charge any defective work, materials or parts relating to the repairs carried out by us appearing within that time but shall not be under any further, or other liability for any other loss or damage whether direct or consequential and our liability shall be limited to the cost of so making good. We do not undertake to bear the cost of fitting any replacement or repaired part.
3. We do not accept liability in respect of parts of proprietary manufacture, e.g. tyres, saddles, chains speedometers, revolution counters and electrical equipment which may be used by us in effecting a repair. All other conditions and warranties statutory or otherwise express or implied are hereby excluded.

TRIUMPH SPARES

HOW TO ORDER. Every part is indicated by number, and this should be quoted together with the description. In order to assist customers, dimensions have been given in many cases where parts are similar. Parts where possible have been listed in order of assembly and a number of the illustrations show the assembly order also. With these aids there should be no difficulty in identifying the parts you require. **Always head your order with the engine number, stamped on the left side of the crank case underneath the cylinder flange, together with the prefix letters.**

WHERE TO OBTAIN. Triumph Spare Parts can only be obtained from an authorised Triumph Dealer, and we recommend our customers to place their orders with the Triumph Dealer in their district. When parts not usually asked for are required, and for which the Dealer may have to write or obtain specially, the postage or carriage incurred becomes payable.

Triumph Spares are not supplied to private owners direct from the factory. If difficulty is experienced in obtaining the required parts, the matter should be taken up directly with the Triumph Spares Department.

Customers are warned against the risk incurred by purchasing parts that are not of genuine Triumph manufacture. This risk is eliminated if parts are ordered as instructed from recognised Dealers.

PATTERNS AND PARTS FOR REPAIR. It is not necessary to send patterns if the part number is quoted. The sending of patterns often delays the order as parcel post or rail takes longer than letter post.

Parts sent to Coventry for repair, replacement, or as patterns should bear the sender's name and address and clear instructions should accompany the parts. In your own interest send a copy of the advice note under separate cover. All parts must be forwarded carriage paid and care should be taken to ensure that all remittances are sent separately and not enclosed with the parts. Fragile units such as cylinders, etc., should always be boxed to avoid damage in transit. Complete machines should have all fitments such as windscreens, driving mirrors, tools, etc., removed by the sender before despatch, as it is impossible for us to accept responsibility in the event of loss in transit. We are always pleased to give estimates for overhauling and repairs, but should an estimate not be accepted, a charge will be made covering cost of dismantling and re-assembling, if carried out.

Communications relating to Parts should be addressed to the SPARES DEPARTMENT and for repairs, guarantee claims and technical advice to the SERVICE DEPARTMENT, Triumph Engineering Co. Ltd., Meriden Works, Allesley, Coventry. In order to facilitate quick reference, the quoting of any number, invoice number or reference from previous communications is essential. Accessories not of our manufacture should be sent direct to the actual makers, whose names and addresses appear below.

PROPRIETARY GROUP

Ancillary equipment which is fitted to our motor cycles is of the highest quality and is guaranteed by the manufacturer and not by ourselves. Any repairs or claims should be made to the actual makers or their local agents who will always give owners every possible assistance. The following are the addresses of the various manufacturers:—

CARBURETTORS
Messrs. Amal Ltd.,
Holdford Rd., Witton, Birmingham 6.

CHAINS
Renold Chains Ltd.,
Wythenshawe, Manchester.

ELECTRICAL EQUIPMENT
Messrs J. Lucas Ltd.,
Gt. Hampton St., Birmingham, 18.

TYRES
Dunlop Rubber Co. Ltd.,
Fort Dunlop,
Birmingham, 24.

SPARKING PLUGS
Champion Sparking Plug Co. Ltd.,
Feltham, Middlesex.

SPEEDOMETERS
Messrs. Smiths Industries Ltd.,
Cricklewood Works, London, N.W.2.

SUSPENSION UNITS
Messrs. Girling Ltd.,
Birmingham Road, West Bromwich, Staffs.

ILLUSTRATION INDEX

<i>Fig. No.</i>	<i>Description</i>	<i>Page No.</i>
1	CRANKSHAFT AND CONNECTING RODS	14
2	CRANKCASE	16
3	OIL PUMP, RELEASE VALVE	18
4	INLET MANIFOLD	20
5	CYLINDER BLOCK AND HEAD, T90	22, 24
6	CYLINDER BLOCK AND HEAD T100S AND T100C	26
7	CYLINDER BLOCK AND HEAD T100R AND T100T	28
8	TIMING COVER AND CONTACT BREAKER	30
9	GEARBOX SHAFTS, BEARINGS AND INNER COVER	32, 34
10	GEARBOX OUTER COVER AND LEVERS	36
11	CLUTCH	38
12	CHAINCASE AND CHAINS	40
13	ENGINE FITTINGS AND EXHAUST SYSTEM	42
14	EXHAUST PIPES, UNDERSHIELDS AND FOOTPEGS (T100C)	44
15	FRAME	46
16	SWINGING FORK, SUSPENSION UNITS AND CHAINGUARD	48
17	TELESCOPIC FRONT FORK, T90 AND T100	50
18	TELESCOPIC FRONT FORK, U.S.A. T100C	52
19	FRONT WHEEL	54
20	REAR WHEEL	56
21	QUICKLY DETACHABLE REAR WHEEL (NOT U.S.A.)	58
22	MUDGUARDS (FENDERS U.S.A.)	60
23	PANELS AND TWINSEAT	62
24	PETROL TANKS	64
25	OIL TANK	66
26	BATTERY, TOOLKIT AND AIR FILTERS	68
27	HANDLEBARS AND CONTROL LEVERS	70
28	CONTROL CABLES	72
29	CARBURETTER, T90, T100S AND T100C	74
30	CARBURETTER, T100T AND T100R	76
31	A.C. MAGNETO IGNITION COILS, DIRECT LIGHTING	78
32	D.C. IGNITION COILS, HORN, RECTIFIER AND ZENER DIODE	80
33	HEADLAMP, WIRING HARNESS, SWITCHES AND TAIL LAMP	82
34	SPEEDOMETER AND TACHOMETER	84

INDEX

	<i>Page</i>		<i>Page</i>
AIR FILTER	69	MANIFOLD	21
ALTERNATOR	15, 41	MUDGUARDS	61
BATTERY CARRIER	69	MUFFLERS	43, 45
CARBURETTER	75, 77	OIL PUMP	19
CARTON PACKS	12	OIL TANK	67
CENTRE STAND	47	PETROL TANK	65
CHAINCASE	41	PILLION FOOTRESTS	47
CHAINS	41	PISTONS	15
CLUTCH	39	PROP STAND	47
COIL	79, 81	Q.D. REAR WHEEL (NOT U.S.A.) ...	59
CONTACT BREAKER	31	REAR PANELS	63
CONTROL CABLES	73	REAR WHEEL	57
CONTROL LEVERS	71	RECTIFIER	81
CRANKCASE	17	SILENCERS	43
CRANKSHAFT	15	SPARK PLUGS	81
CYLINDER HEAD	23, 25, 27, 29	SPEEDOMETER	85
ENGINE PLATES	43	STEERING RACES	47
EXHAUST PIPES	43, 45	SUSPENSION UNITS	49
FENDERS	61	SWITCHES	83
FOOTRESTS	45, 47	TACHOMETER	85
FRONT FORKS	51, 53	TIMING GEARS	15
FRONT WHEEL	55	TOOLKIT	69
GAS TANK	65	TWINSEAT	63
GASKET SETS	12	VALVES	23, 25, 27, 29
GEARBOX	33, 35, 37	WIRING HARNESS	79, 83
HANDLEBARS	71		
HORN	79, 81		

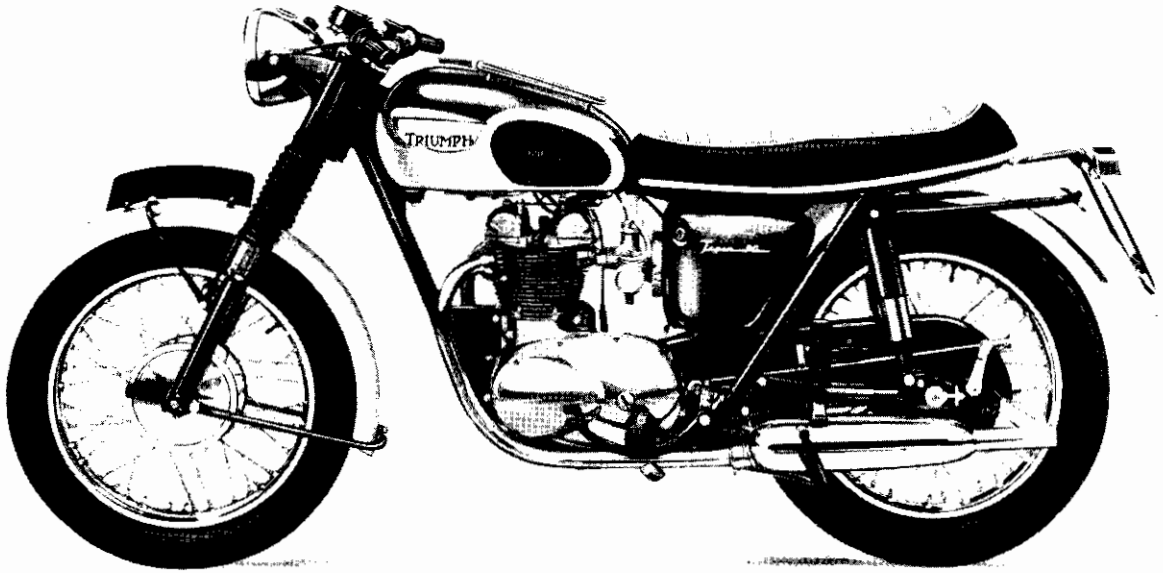

TIGER 90 (T90) TECHNICAL DATA

Bore and Stroke		58.25 x 65.5 mm. 2.292 x 2.578 ins.
Capacity		348 c.c. (21.23 cu. ins.)
Compression Ratio		9.5 : 1
Sparking Plugs		Champion N4
Carburetter		Amal Monobloc
	Main Jet	180
	Needle Jet	.106
	Needle	Type C
	Throttle Valve	37 $\frac{6}{8}$ / $\frac{1}{2}$
	Pilot Jet	20
Gearbox Sprocket		17 teeth
Chains	Front	$\frac{3}{8}$ in. Duplex x 78 links
	Rear	$\frac{5}{8}$ in. x $\frac{1}{8}$ in. x 102 links
Capacities	Fuel Tank	3 galls. (13.5 litres)
	Oil Tank	6 pints (3.5 litres)
	Gearbox	$\frac{2}{3}$ pint (375 c.c.)
	Primary Chaincase	$\frac{1}{2}$ pint (300 c.c.)
	Front Forks (each leg)	$\frac{1}{4}$ pint (190 c.c.)
Brakes	Front and Rear, diameter	7 in. (17.78 cm.)
Tyre Size	Front	3.25 x 18
	Rear	3.50 x 18

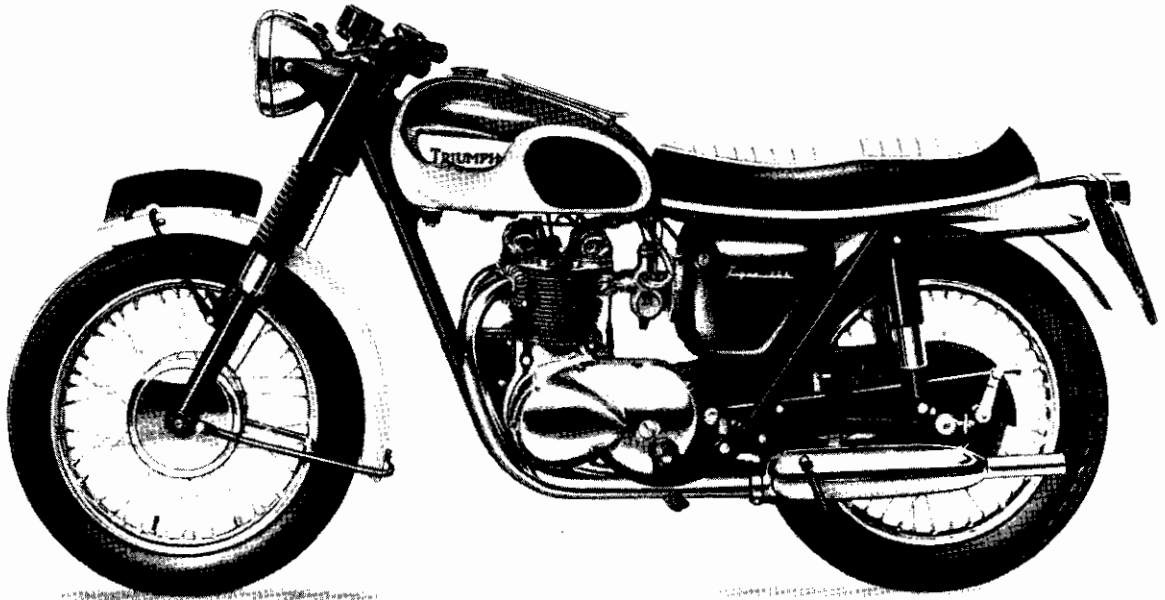

TIGER 100 (T100S) TECHNICAL DATA

Bore and Stroke		69 x 65.5 mm. 2.716 x 2.578 ins.
Capacity		490 c.c. (29.8 cu. ins.)
Compression Ratio		9 : 1
Sparking Plugs		Champion N4
Carburetter		Amal Monobloc
	Main Jet	190
	Needle Jet	.106
	Needle	Type C
	Throttle Valve	376/3½
	Pilot Jet	25
Gearbox Sprocket		18 teeth
Chains	Front	¾ in. Duplex x 78 links
	Rear	¾ in. x ¾ in. x 102 links
Capacities	Fuel Tank	3 galls. (13.5 litres)
	Oil Tank	6 pints (3.5 litres)
	Gearbox	2/3 pint (375 c.c.)
	Primary Chaincase	½ pint (300 c.c.)
	Front Forks (each leg)	⅓ pint (190 c.c.)
Brakes	Front and Rear, diameter	7 in. (17.18 cm.)
Tyre Size	Front	3.25 x 18
	Rear	3.50 x 18

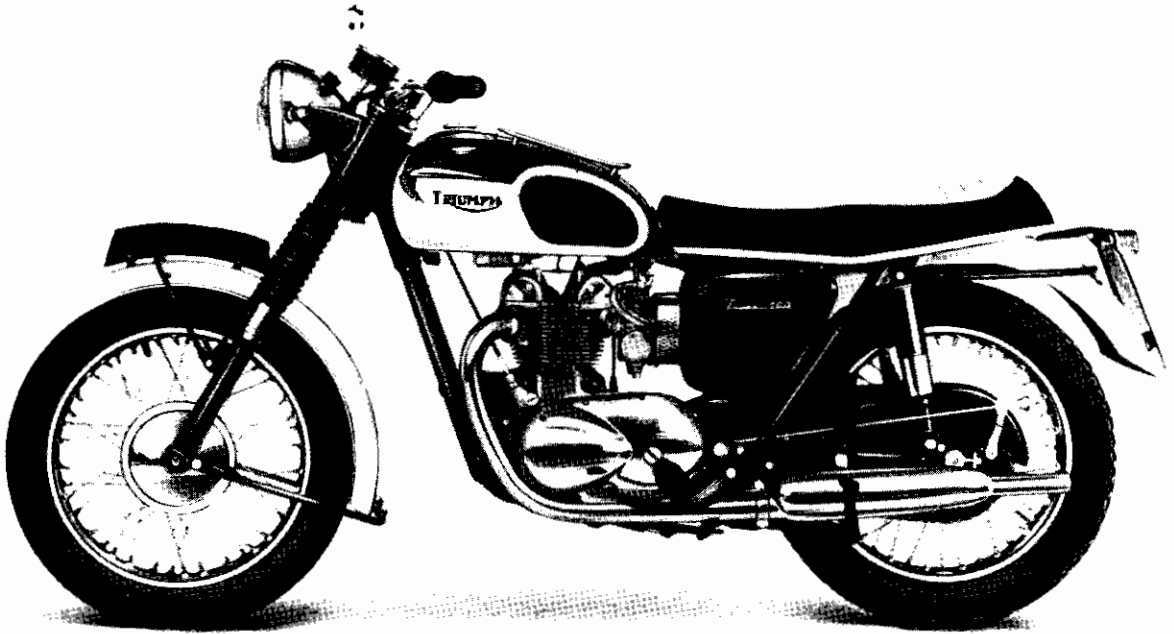

TIGER 100 (T100T) TECHNICAL DATA

Bore and Stroke		2.716 x 2.578 ins.
Capacity		29.8 cu. ins.
Compression Ratio		9.75 : 1
Sparking Plugs		Champion N4
Carburettor		Amal Monobloc
	Main Jet	200
	Needle Jet	.106
	Needle	Type C
	Throttle Valve	376/3½
	Pilot Jet	25
Gearbox Sprocket		18 teeth
Chains	Front	¾ in. Duplex x 78 links
	Rear	¾ in. x ¾ in. x 102 links
Capacities	Gas Tank	3 galls. (13.5 litres)
	Oil Tank	6 pints (3.5 litres)
	Gearbox	2/3 pint (375 c.c.)
	Primary Chaincase	½ pint (300 c.c.)
	Front Forks (each leg)	⅓ pint (190 c.c.)
Brakes	Front and Rear, diameter	7 in. (17.18 cm.)
Tyre Size	Front	3.25 x 18
	Rear	3.50 x 18

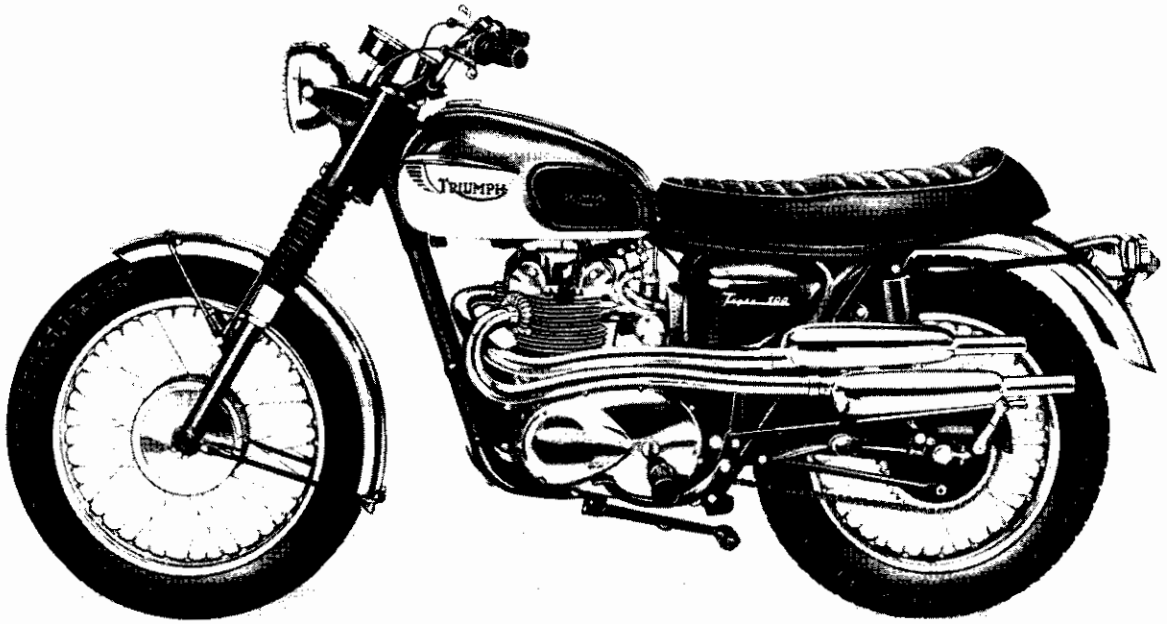

U.S.A. TIGER 100 (T100C) TECHNICAL DATA

Bore and Stroke		2.716 x 2.578 ins.
Capacity		29.8 cu. ins.
Compression Ratio		9 : 1
Sparking Plugs		Champion N4
Carburetter		Amal Monobloc
	Main Jet	190
	Needle Jet	.106
	Needle	Type C
	Throttle Valve	37/6/3½
	Pilot Jet	25
Gearbox Sprocket		18 teeth
Chains	Front	¾ in. Duplex x 78 links
	Rear	¾ in. x ¾ in. x 102 links
Capacities	Gas Tank	2¾ U.S. galls.
	Oil Tank	6 U.S. pints
	Gearbox	2/3 pint (375 c.c.)
	Primary Chaincase	½ pint (300 c.c.)
	Front Forks (each leg)	¼ pint (190 c.c.)
Brakes	Front and Rear, diameter	7 in. (17.18 cm.)
Tyre Size	Front	3.50 x 19
	Rear	4.00 x 18

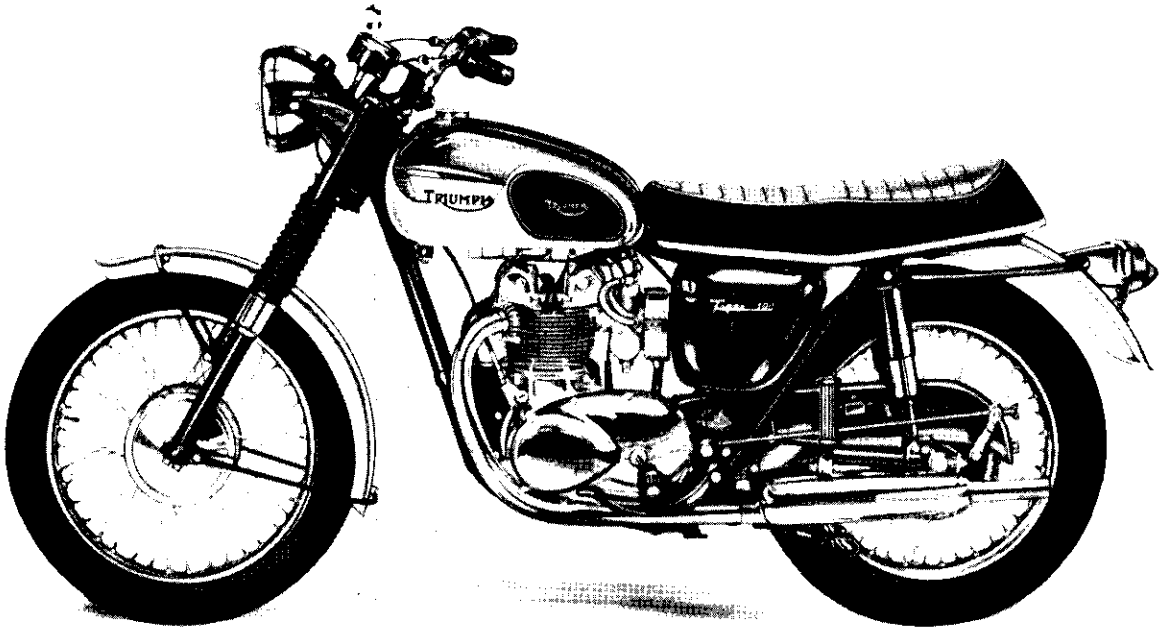

U.S.A. TIGER 100 (T100R) TECHNICAL DATA

Bore and Stroke		2.716 x 2.578 ins.
Capacity		29.8 cu. ins.
Compression Ratio		9.75 : 1
Sparking Plugs		Champion N4
Carburetters		Amal Monobloc
	Main Jet	200
	Needle Jet	.106
	Needle	Type C
	Throttle Valve	376/3½
	Pilot Jet	25
Gearbox Sprocket		19 teeth
Chains	Front	⅜ in. Duplex x 78 links
	Rear	⅝ in. x ⅜ in. x 103 links
Capacities	Gas Tank	2⅓ U.S. Galls.
	Oil Tank	6 U.S. pints
	Gearbox	2/3 pint (375 c.c.)
	Primary Chaincase	½ pint (300 c.c.)
	Front Forks (each leg)	⅓ pint (190 c.c.)
Brakes	Front and Rear, diameter	7 in. (17.18 cm.)
Tyre Size	Front	3.25 x 19
	Rear	4.00 x 18

CARTON PACK LIST

The following sub-assemblies are supplied in carton packs under the part number stated. The contents of these carton packs are preserved and will not deteriorate under adverse conditions.

Part No.	Contents		
PISTONS (c/w rings, gudgeon pins and circlips)			
E.6908	7.5 : 1 C.R.	350 c.c.	Low grade fuel
E.6899	9.5 : 1 C.R.	350 c.c.	Standard T.90
E.6906	7.0 : 1 C.R.	500 c.c.	Low grade fuel
E.6897	9.0 : 1 C.R.	500 c.c.	T.100S, T.100C
E.6884	9.75 : 1 C.R.	500 c.c.	T.100R, T100T
All piston assemblies are available in 0.010 in., 0.020 in., 0.040 in., oversizes (0.25 m.m., 0.5 m.m., 1.0 m.m.).			
BRAKE LININGS			
C.P. 38/AM2	2 16	NW243 W129	Brake lining Rivet
VALVES (Single carburetter T.100)			
C.P. 176	2 2	E4012 E.4013	Inlet valve Exhaust valve
VALVE SPRINGS (all models)			
C.P.177	4 4	E5946 E4011	Inner valve spring Outer valve spring
De-coke Gasket Set	All models	D/GS 6	

r:

HOW TO USE THIS PARTS CATALOGUE



First check that the engine number of your machine is subsequent to that quoted on the title page.

Next consult the index on Page 5 for the parts or group of parts which you wish to locate. When you have located the parts make sure from the end columns that the part you have located does apply to your machine.

List the quantities required as single units: do not ask for "2 pairs" or "3 dozen".

In case of painted items always state the colour required. Painted parts are available only in the colours or alternatives specified for that model of that particular year.

<i>Model</i>	<i>Colour</i>	<i>Suffix Letter to Part No.</i>
T90	HI-FI SCARLET/ALASKAN WHITE	HF/AW
T100	PACIFIC BLUE/ALASKAN WHITE	PB/AW

N.B. Pacific Blue is a flamboyant finish applied over Silver Sheen.

Hi-Fi Scarlet is also flamboyant, and applied over Gold.

Paint is available also in all colours in $\frac{1}{4}$ pint or 1 gallon tins, or Aerosol containers.

PLEASE NOTE

THROUGHOUT THIS LIST, ASSEMBLIES ARE PRINTED IN CAPITALS AND THE COMPONENTS INCLUDED IN THAT ASSEMBLY ARE INDENTED IN THE DESCRIPTION COLUMN, REVERTING TO THE ORIGINAL ALIGNMENT WHEN THE ASSEMBLY IS COMPLETE. TO ORDER THE COMPLETE ASSEMBLY IT IS NECESSARY ONLY TO QUOTE THE ASSEMBLY NUMBER. ANY COMPONENT PARTS LISTED MAY ALSO BE OBTAINED SEPARATELY IF REQUIRED.

SPECIAL WORKSHOP TOOLS

A COMPLETE LIST OF WORKSHOP TOOLS CAN BE MADE AVAILABLE BY EITHER CONTACTING YOUR DEALER OR APPLYING DIRECT TO THE TRIUMPH SERVICE DEPARTMENT. IN MOST CASES THESE TOOLS ARE VERY COSTLY AS THEY ARE MADE ENTIRELY FOR WORKSHOP USE, AND THEREFORE, IT IS NOT RECOMMENDED THAT THE PRIVATE OWNER PURCHASES THE TOOLS IN ORDER TO AID SERVICING THE MACHINE ONCE OR TWICE ONLY. IN THESE CIRCUMSTANCES IT IS FAR MORE ECONOMICAL TO GET IN TOUCH WITH A RECOGNISED DEALER.

UNIFIED THREAD FORM

NEW PARTS HAVING THREADED FIXINGS INTRODUCED IN THIS CATALOGUE HAVE THE UNIFIED FORM OF SCREW THREADS. THIS CHANGEOVER WILL BE CONTINUED AS AND WHEN NEW PARTS ARE INTRODUCED. EVEN WHERE PARTS ARE SIMILAR IN APPEARANCE NEW PART NUMBERS WILL BE ALLOCATED TO IDENTIFY THE UNIFIED THREADS. ALL NUTS, BOLTS AND STUDS HAVING THIS THREAD ARE IDENTIFIED BY MARKINGS. BOLTS HAVE A CIRCULAR RECESS IN THEIR HEADS, STUDS A CIRCULAR GROOVE ON THE END, AND NUTS HAVE INTERLOCKING CIRCLES ON THE SIDE.

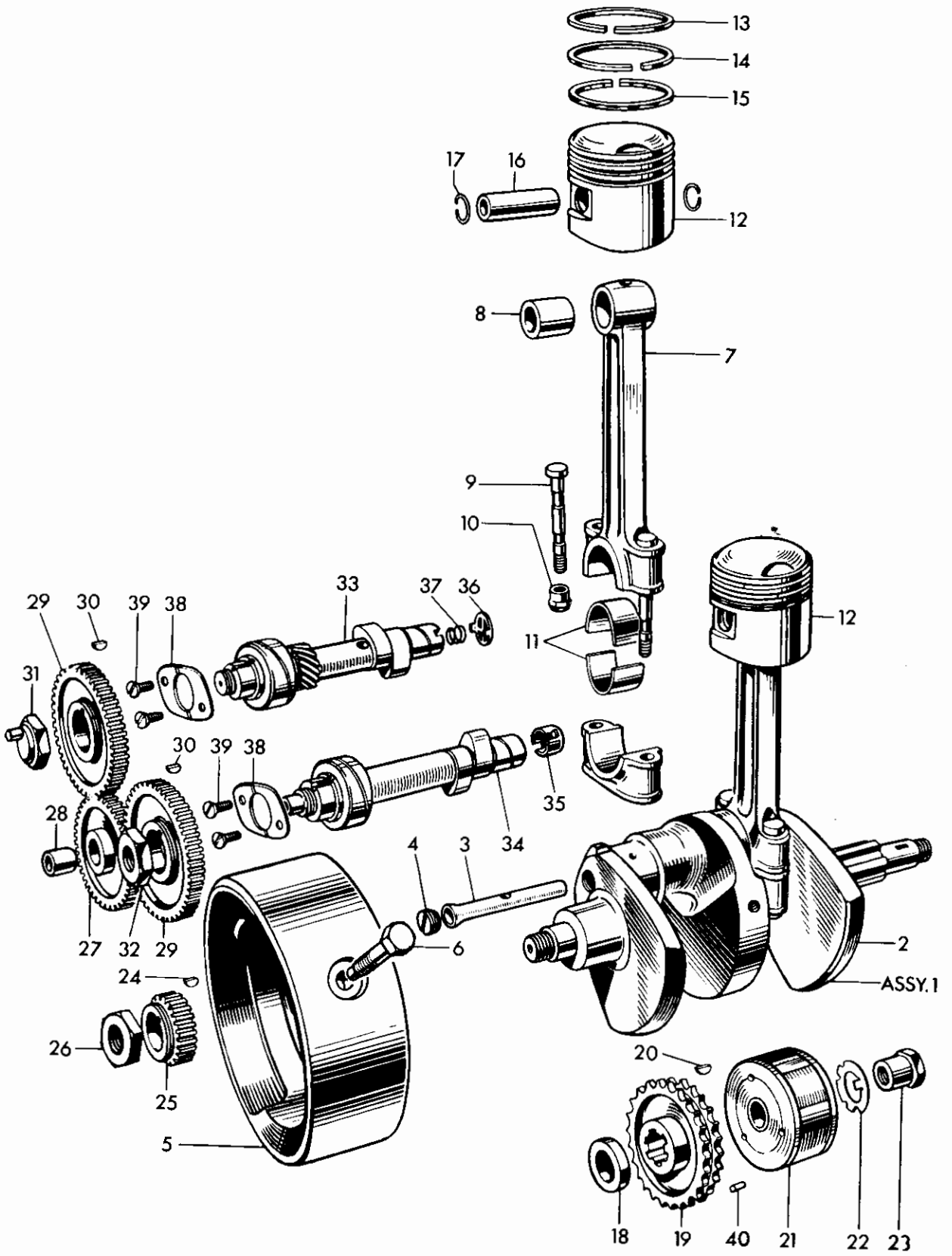

Fig. 1. CRANKSHAFT AND CONNECTING RODS

CRANKSHAFT AND CONNECTING RODS

1	E5869	CRANKSHAFT AND FLYWHEEL ASSEMBLY	1	
2	E3998	Crankshaft	1	
3	E3999	Oil tube	1	
4	E3711	Screwed plug	1	
5	E5870	Flywheel	1	
6	*E3713	Flywheel bolt	3	
7	E6964	CONNECTING ROD	2	T90
7	E4001T	CONNECTING ROD	2	T100
8	E1762	Small end bush	2	T90
8	E4003	Small end bush	2	T100
9	E3705	Connecting rod bolt	2	
10	E2922	Self-locking nut	2	
11	E3706	Big end bearing	4	
12	E6899	PISTON COMPLETE C.R. 9.5:1	2	T90
12	E6897	PISTON COMPLETE C.R. 9:1	2	T100S, T100C
12	E6884	PISTON COMPLETE C.R. 9.75:1	2	T100R, T100T
13	E6902	Plain compression ring	2	T90
13	E6893	Taper compression ring	4	T100
14	E6903	Taper compression ring	2	T90
15	E6904	Oil control ring	2	T90
15	E6894	Oil control ring	2	T100
16	E6901	Gudgeon pin	2	T90
16	E6861	Gudgeon pin	2	T100
17	E6905	Circlip	4	T90
17	E6869	Circlip	4	T100
18	E4006	Distance collar	1	
19	E4141	Engine sprocket, 26T Duplex	1	
20	E3851	Rotor key	1	
21	54213901	Rotor, type RM 19	1	
21	54215824	Rotor, type RM19	1	A.C. ignition
22	E3975	Tab washer	1	
23	E3735	Nut	1	
24	E1580	Key	1	
25	E1771	Timing pinion	1	
26	E398	Nut	1	
27	E6160	INTERMEDIATE WHEEL	1	
28	E400	Bush	1	
29	E1486A	Camshaft wheel...	2	
30	E1558	Camshaft key	2	
31	E1463	Inlet camshaft nut	1	
32	E4563	Exhaust camshaft nut	1	
33	E4678	Inlet camshaft	1	
34	E6965	Exhaust camshaft	1	T100T, T100R
34	E4786	EXHAUST CAMSHAFT	1	T100S, T100C
35	†E4700	Tachometer drive thimble	1	
36	E5316	Rotary breather valve	1	
37	E2256	Breather valve spring	1	
38	E3727	Retaining plate	2	
39	E3728	Screw (15/32 in. U.H.)	4	
40	E4142	Dowel	1	

* Use DS24 Loctite sealant

† Use E7050 to replace without dismantling

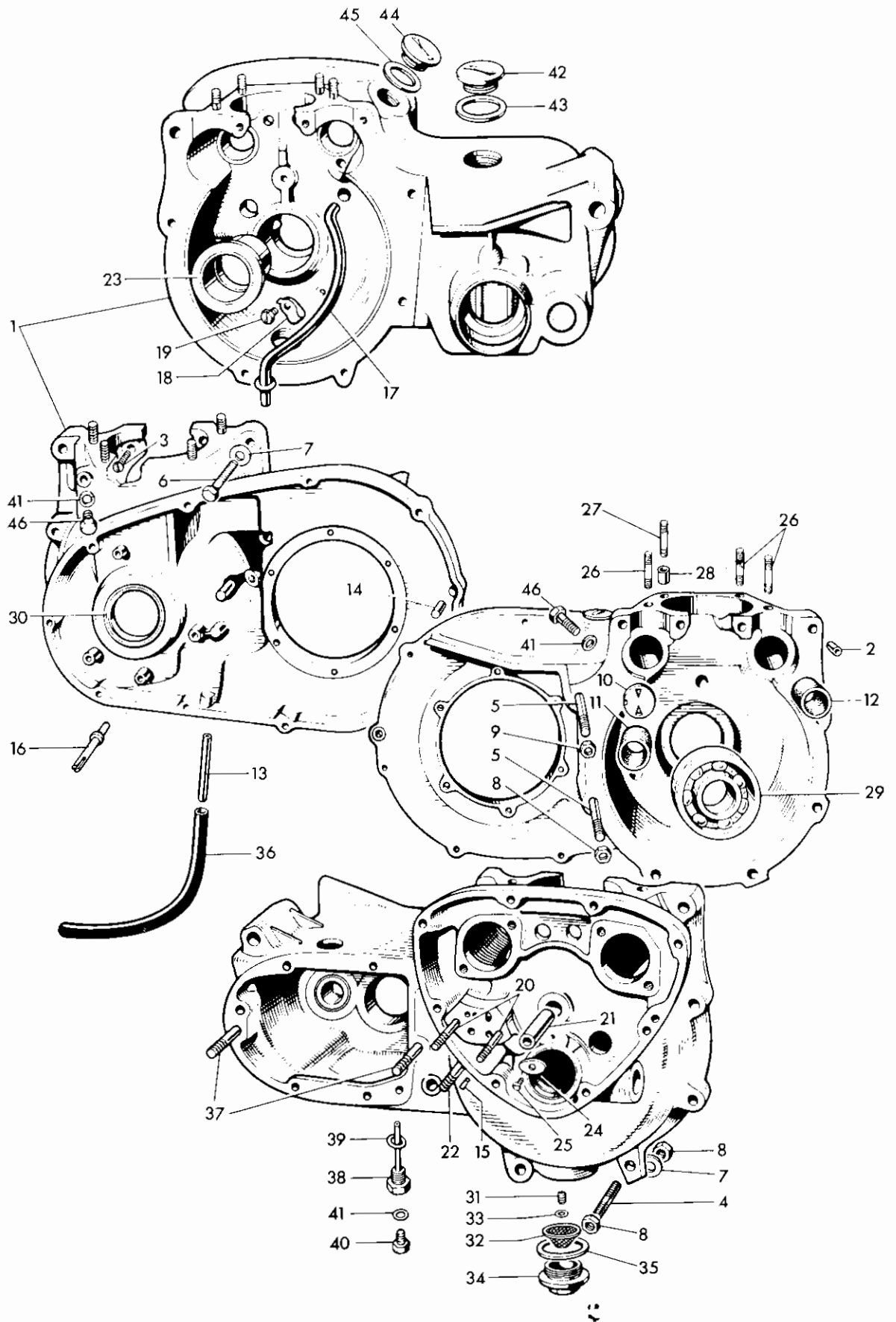

Fig. 2. CRANKCASE

Ref. No.	Part No.	DESCRIPTION	QUANTITY	REMARKS
		CRANKCASE		
1	E5868/4645	CRANKCASE c/w STUDS AND RIGHT MAIN BEARING	1	
2	E3716	Hollow dowel	1	
3	E3859	Screw (21/32 in. U.H.)	2	
4	E3804	Stud (3 in. O.A.)	1	
5	E3803	Stud (3 3/4 in. U.H.)	2	
6	E3799	Bolt (1 5/8 in. U.H.)	1	
7	S25-3	Plain washer	3	
8	S1-51	Nut	3	
9	E1310	Nut	1	
10	E3822	Breather disc	1	
11	E3824	Inlet camshaft bush	1	
12	E3823	Exhaust camshaft bush	1	
13	E2724	Breather pipe	1	
14	E6076	Blanking plug	1	Not serviced
15	E6386	Dowel	1	Not serviced
16	E4147	Chain tensioner abutment	1	
17	E3719	Oil scavenge pipe	1	
18	E1509	Clip	1	
19	E1645	Screw (17/64 in. U.H.)	1	
20	E3718	Oil pump stud (1 1/8 in. O.A.)	2	
21	E375	Intermediate wheel spindle	1	
22	E3717	Oil pipes stud (1 1/2 in. O.A.)	1	
23	E4322	Right main bearing	1	
24	E4139	Locating plate	1	
25	E4140	Self-tapping screw	1	
26	E3820	Cylinder stud (1 1/2 in. O.A.)	6	
27	E3819	Cylinder stud (1 1/8 in. O.A.)	2	
28	E1534A	Dowel	2	
29	E3835	Left main bearing (Ball-journal)	1	
30	E3876	Oil seal	1	
31	E3724	Filter spring	1	
32	E3722	Filter	1	
33	E3723	Sealing washer	1	
34	E1564	Filter cap	1	
35	E1577	Joint washer	1	
36	E3078	Breather extension rubber pipe	1	
37	T1399	Stud (3 1/8 in. O.A.)	2	
38	T1112	Drain plug (with level tube)	1	
39	WE 170	Fibre washer	1	
40	T361	Level plug	1	
41	T1257	Fibre washer	3	
42	E732	Filler plug	2	
43	NE507	Fibre washer	2	
44	E4587	Distributor hole plug	1	
45	E4593	Fibre washer	1	
46	E4706	Tachometer drive plug	2	

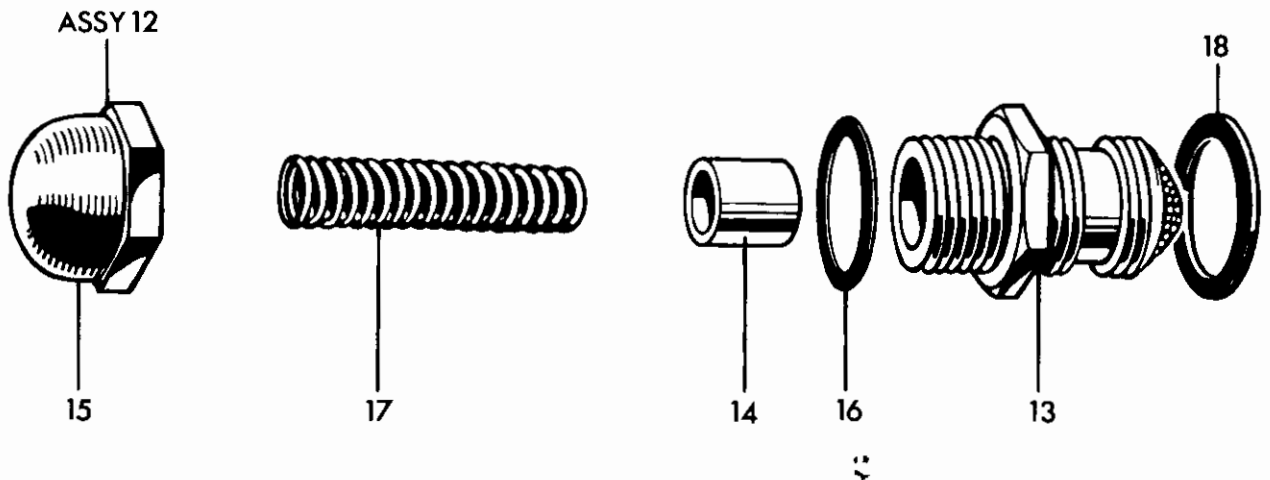
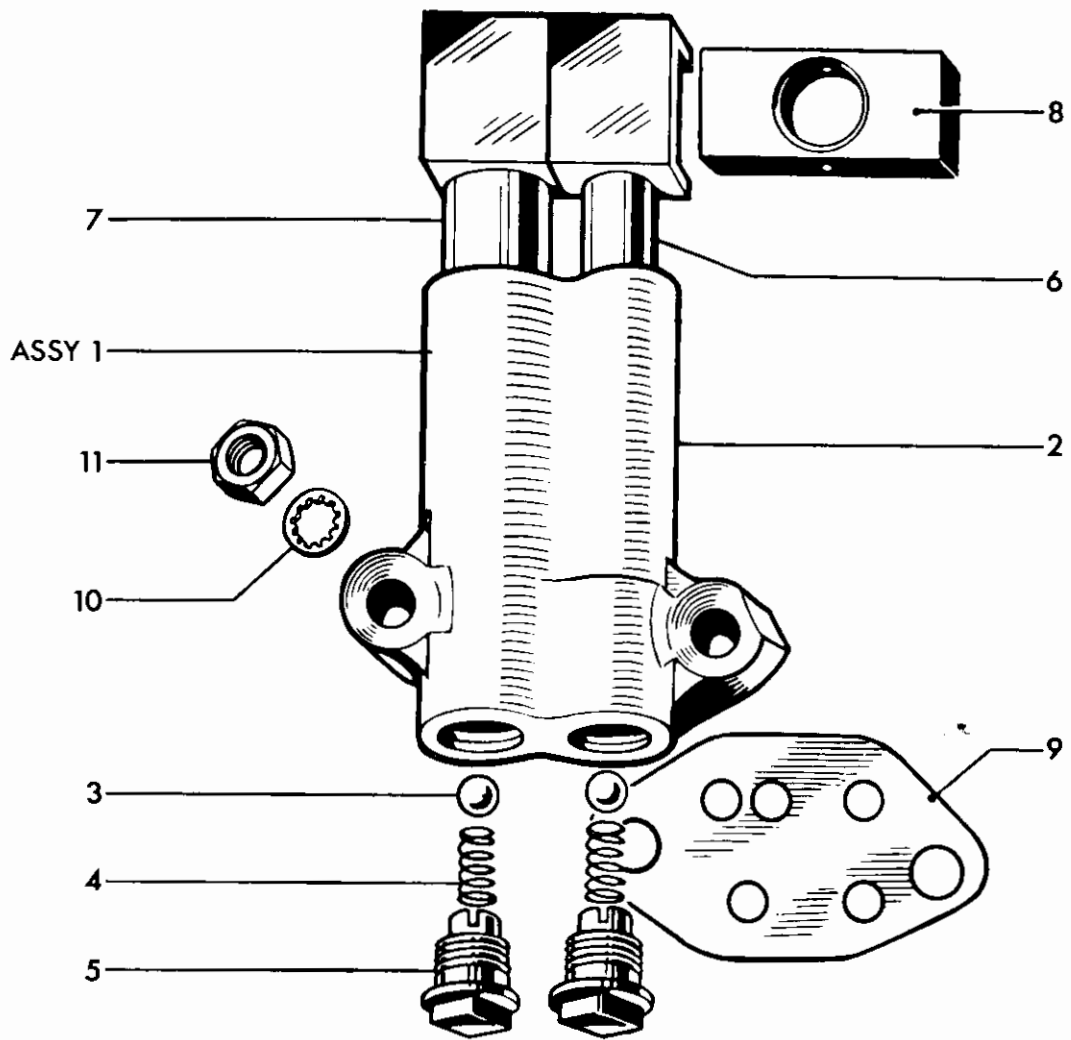

Fig. 3. OIL PUMP AND RELEASE VALVE

Ref. No.	Part No.	DESCRIPTION	QUANTITY	REMARKS
----------	----------	-------------	----------	---------

OIL PUMP AND RELEASE VALVE

1	E6928	OIL PUMP	1	
2	E6680	Pump body...	1	
3	S70-7	Valve ball	2	
4	E403	Valve spring	2	
5	E2360	Screwed plug	2	
6	GS153	Feed plunger	1	
7	E6681	Scavenge plunger	1	
8	E495	Drive block	1	
9	E3730	Joint washer	1	
10	E3887	Serrated washer	2	
11	E3732	Nut	2	
12	E5896	OIL RELEASE VALVE	1	
13	E2794	Valve body	1	
14	GS251	Piston	1	
15	E2304	Cap	1	
16	GS254	Fibre washer	1	
17	E6062	Main spring	1	
18	E1670	Fibre washer	1	

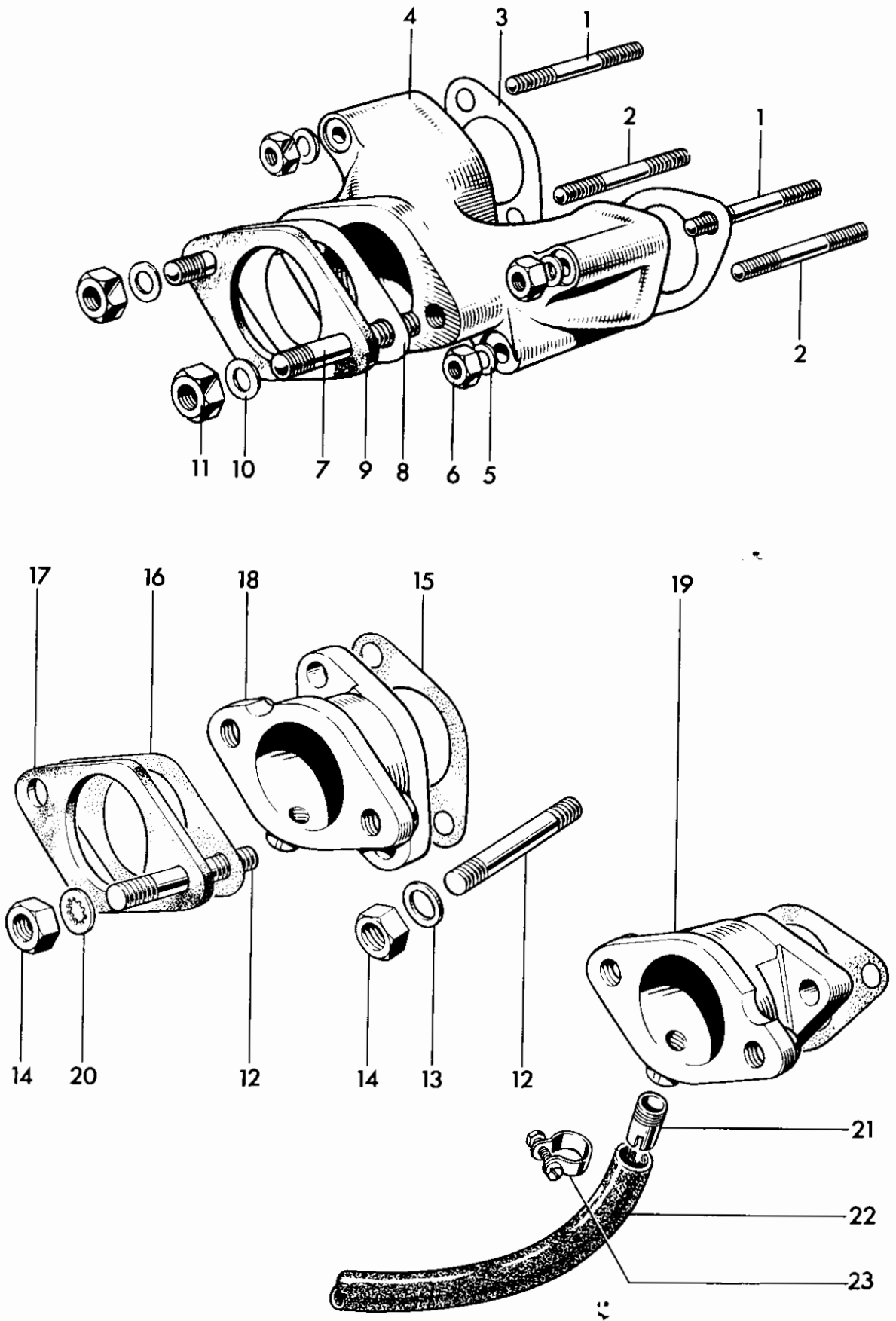

Fig. 4. INLET MANIFOLDS

INLET MANIFOLDS

Single Carburetter Models (T90, T100, T100C)

1	E3796	Stud (1 $\frac{1}{2}$ in. O.A.)	2	
2	E3797	Stud (2 in. O.A.)	2	
3	E2967	Joint washer	2	
4	E4689	Inlet manifold	1	
5	S25-13	Plain washer	4	
6	W103	Nut	4	
7	E3880	Stud (1 $\frac{1}{4}$ in. O.A.)	2	
8	NA43A	Joint washer	1	
9	E4504	Insulating block	1	T90
9	E2968	Insulating block	1	T100
10	S25-13	Plain washer	2	
11	S1-51	Nut	2	

Twin Carburetter Models (T100T, T100R)

12	S582	Stud	8	
13	S25-13	Plain washer	4	
14	15105/00/2	Nut, locking	8	
15	E6772	Joint washer, manifold	2	
16	NA43A	Joint washer, insulating block	2	
17	E2968	Insulating block	2	
18	E7136	Left manifold	1	
19	E7137	Right manifold	1	
20	E2287	Serrated washer	4	
21	E6916	Connector	2	
22	E6958	Balance pipe	1	
23	E5473	Clip	2	

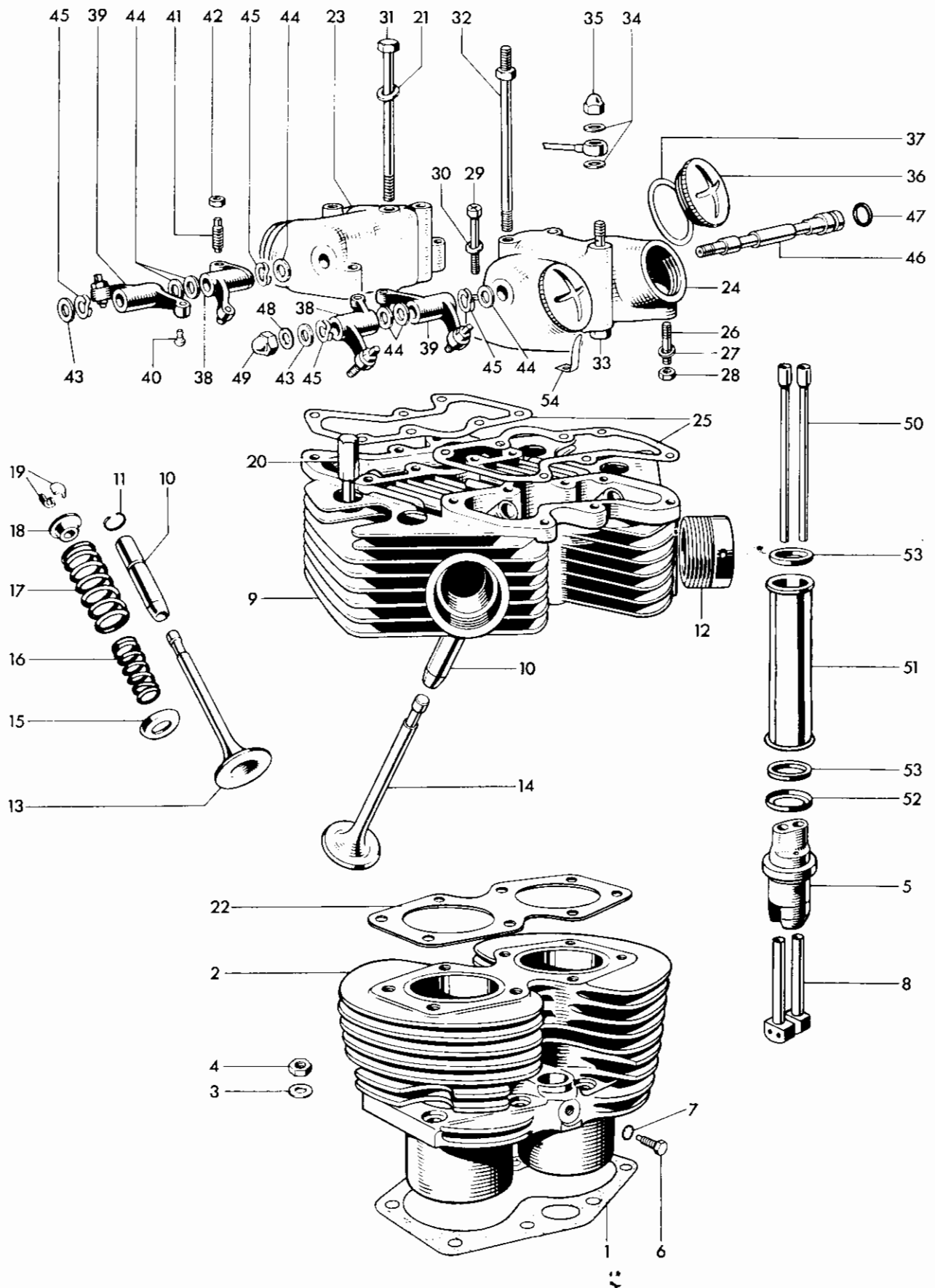

Fig. 5. CYLINDER BLOCK AND HEAD, T90

CYLINDER BLOCK AND HEAD, T90

1	E6923	Cylinder base washer	1	
2	E3698	Cylinder block	1	
3	GS308	Plain washer	8	
4	E2412	Nut	8	
5	E4676	Tappet guide block	2	
6	H200	Tappet block screw ($\frac{7}{8}$ in. U.H.)	2	
7	E1612	Serrated washer	2	
8	E3753	Tappet	4	
9	E6699	CYLINDER HEAD c/w GUIDES	1	
10	E6301	Valve guide	4	
11	E3209	Valve guide circlip	4	
12	E2961	Exhaust pipe adaptor	2	
13	E4640	Inlet valve	2	
14	E3739	Exhaust valve	2	
15	E3740	Bottom cup	4	
16	E5946	Inner valve spring	4	
17	E4011	Outer valve spring	4	
18	E3742	Top collar	4	
19	WE259A	Split cotter	8	
20	E4456	Cylinder head bolt (2 $\frac{25}{32}$ in. U.H.)	4	
21	F2184	Plain washer	8	
22	E4674	Cylinder head gasket	1	
23	E3745	Inlet rocker box	1	
24	E3744	Exhaust rocker box	1	
25	E3743	Joint washer	2	
26	E3858	Rocker box stud ($\frac{15}{8}$ in. O.A.)	4	
27	E3302	Plain washer	4	
28	F879	Nut	4	
29	E3668	Screw ($\frac{15}{8}$ in. U.H.)	4	
30	E3857	Plain washer	4	
31	E3794	Cylinder head bolt (5 $\frac{7}{8}$ in. U.H.)	2	
32	E3795	Cylinder head torque stay bolt	2	
33	E3809	Oil feed bolt	2	
34	F1880	Copper washer	6	
35	H400	Domed nut	2	
36	E4610	Inspection cap	4	
37	E3751	Fibre washer	4	
38	E3749	ROCKER (Right exhaust, left inlet)	2	
39	E3750	ROCKER (Left exhaust, right inlet)	2	
40	E3222	Rocker ball pin	4	
41	E3223	Rocker adjusting pin	4	
42	GS662	Adjuster lock nut	4	
43	E1330	Thrust washer, $\frac{3}{8}$ in.	2	
44	E2534	Thrust washer, $\frac{7}{8}$ in.	6	
45	E3224	Spring washer	4	
46	E3748	Rocker spindle	2	
47	E3253	Sealing rubber	2	
48	E1335	Copper washer	2	

(Continued)

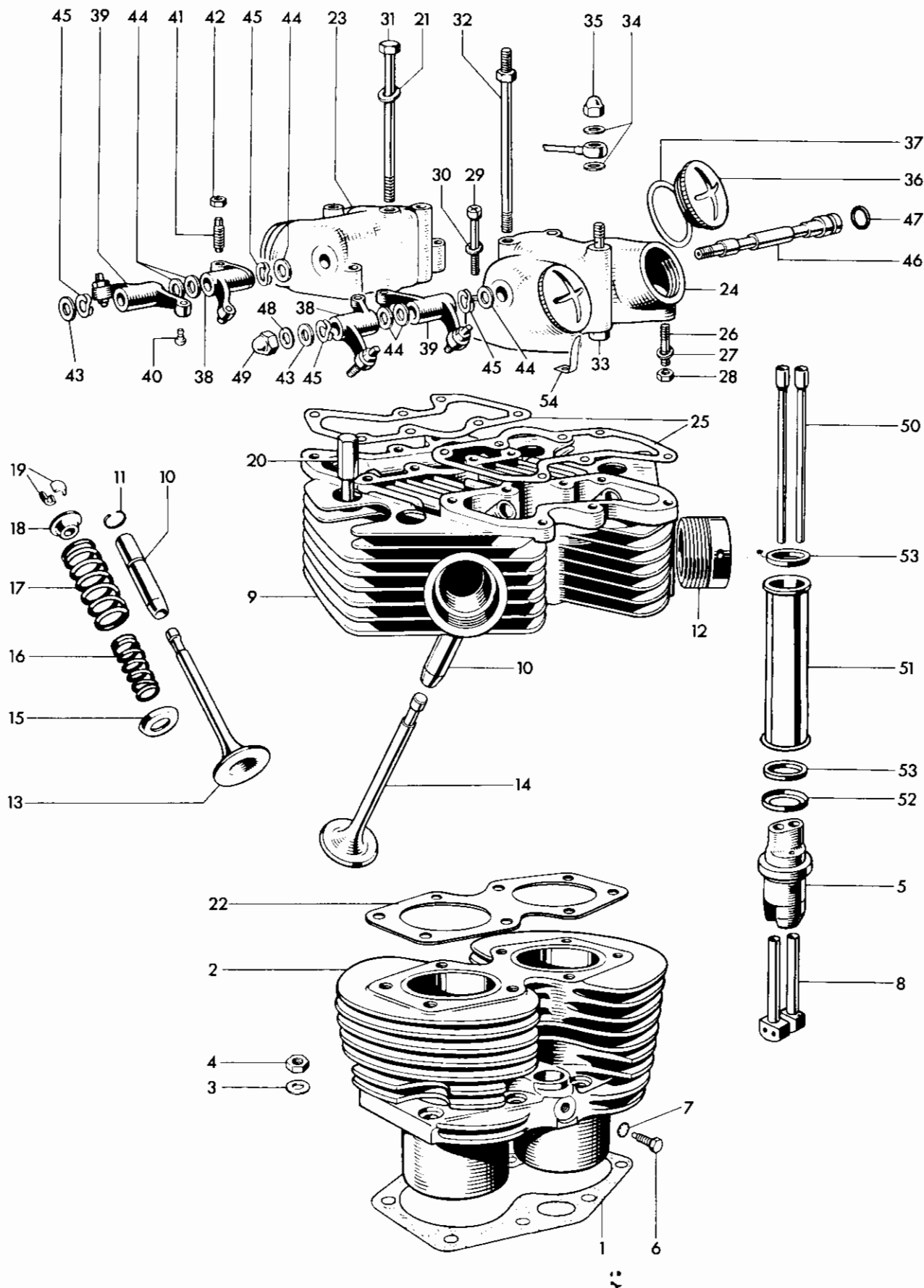

Fig. 5. CYLINDER BLOCK AND HEAD, T90

Ref. No.	Part No.	DESCRIPTION	QUANTITY	REMARKS
----------	----------	-------------	----------	---------

CYLINDER BLOCK AND HEAD, T90
 (Continued)

49	E1435	Domed nut	2
50	E3759	Push rod	4
51	E4751	Cover tube	2
52	E4746	Bottom cup	2
53	E4752	Rubber washer	4
54	E4671	Locking spring	4

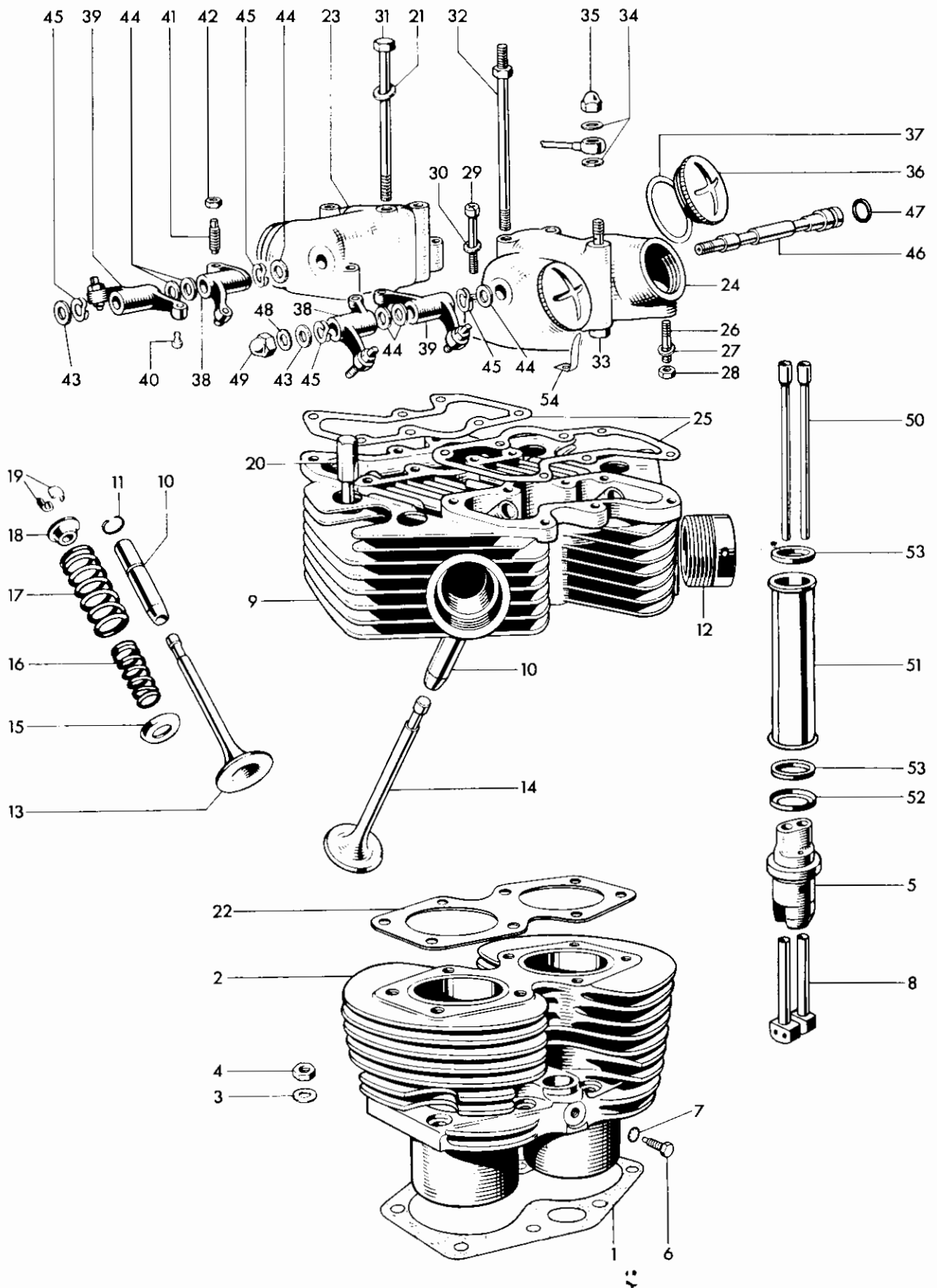

Fig. 6. CYLINDER BLOCK AND HEAD, T100S AND T100C

Ref. No.	Part No.	DESCRIPTION	QUANTITY	REMARKS
CYLINDER BLOCK AND HEAD, T100S, T100C SINGLE CARBURETTER				
1	E6923	Cylinder base washer	1	
2	E4000	Cylinder block	1	
3	GS308	Plain washer	8	
4	E2412	Nut	8	
5	E4676	Tappet guide block	2	
6	H200	Tappet block screw ($\frac{7}{16}$ in. U.H.)	2	
7	E1612	Serrated washer	2	
8	E3753	Tappet	4	
9	E6700	CYLINDER HEAD c/w GUIDES	1	
10	E6301	Valve guide	4	
11	E3209	Valve guide circlip	4	
12	E2961	Exhaust pipe adaptor	2	
13	E6853	Inlet valve	2	
14	E4012	Exhaust valve	2	
15	E4013	Bottom Cup	4	
16	E3740	Inner valve spring	4	
17	E4011	Outer valve spring	4	
18	E3742	Top collar	4	
19	WE259A	Split cotter	8	
20	E4456	Cylinder head bolt (2 $\frac{25}{32}$ in. U.H.)	4	
21	F2184	Plain washer	8	
22	E4675	Cylinder head gasket	1	
23	E3745	Inlet rocker box	1	
24	E3744	Exhaust rocker box	1	
25	E3743	Joint washer	2	
26	E3858	Rocker box stud ($\frac{1}{8}$ in. O.A.)	4	
27	E3302	Plain washer	4	
28	F879	Nut	4	
29	E3668	Screw ($\frac{1}{8}$ in. U.H.)	4	
30	E3857	Plain washer	4	
31	E3794	Cylinder head bolt (5 $\frac{7}{8}$ in. U.H.)	2	
32	E3795	Cylinder head torque stay bolt	2	
33	E3809	Oil feed bolt	2	
34	F1880	Copper washer	6	
35	E400	Domed nut	2	
36	E4610	Inspection cap	4	
37	E3751	Fibre washer	4	
38	E3749	ROCKER (right exhaust, left inlet)	2	
39	E3750	ROCKER (left exhaust, right inlet)	2	
40	E3222	Rocker ball pin	4	
41	E3223	Rocker adjusting pin	4	
42	GS662	Adjuster lock nut	4	
43	E1330	Thrust washer, $\frac{3}{8}$ in.	4	
44	E2534	Thrust washer, $\frac{7}{8}$ in.	6	
45	E3224	Spring washer	2	
46	E3748	Rocker spindle	2	
47	E3253	Sealing rubber	2	
48	E1335	Copper washer	2	
49	E1435	Domed nut	2	
50	E4008	Push rod	4	
51	E4751	Cover tube	2	
52	E4746	Bottom cup	2	
53	E4752	Rubber washer	4	
54	E4671	Locking spring	4	

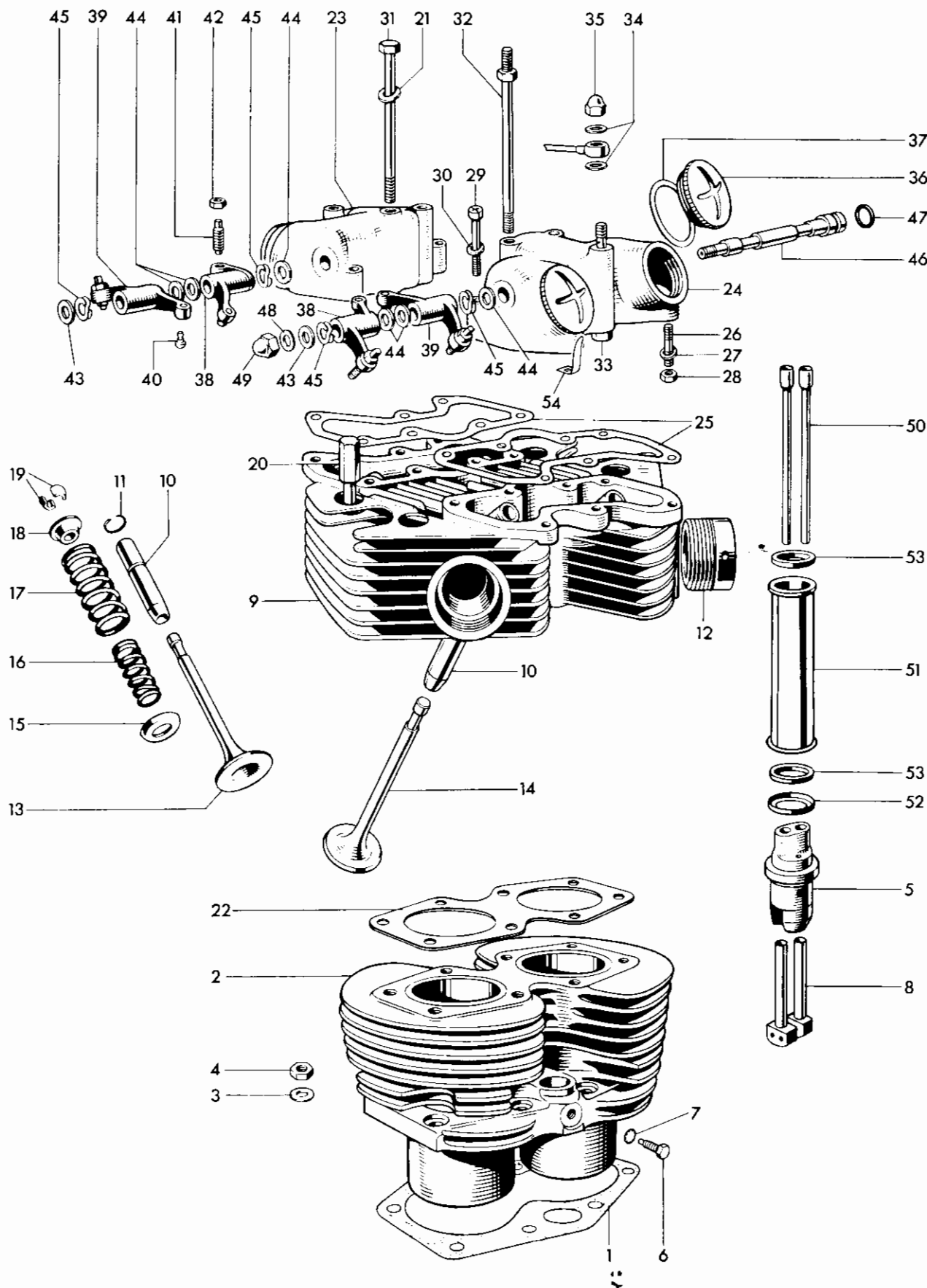

Fig. 7. CYLINDER BLOCK AND HEAD, T100R, T100T.

CYLINDER BLOCK AND HEAD, T100R, T100T TWIN CARBURETTER

1	E6923	Cylinder base washer	1	
2	E4000	Cylinder block	1	
3	GS308	Plain washer	8	
4	E2412	Nut	8	
5	E4676	Tappet guide block	2	
6	H200	Tappet block screw ($\frac{7}{16}$ in. U.H.)	2	
7	E1612	Serrated washer	2	
8	E4040	Tappet	4	
9	E6966	CYLINDER HEAD c/w GUIDES	1	
10	E6301	Valve guide	4	
11	E3209	Valve guide circlip	4	
12	E2961	Exhaust pipe adaptor	2	
13	E6853	Inlet valve	2	
14	E6584	Exhaust valve	2	
15	E6855	Bottom Cup	4	
16	E5946	Inner valve spring	4	
17	E4011	Outer valve spring	4	
18	E3742	Top collar	4	
19	WE259A	Split cotter	8	
20	E4456	Cylinder head bolt (2 $\frac{25}{32}$ in. U.H.)	4	
21	F2184	Plain washer	8	
22	E4675	Cylinder head gasket	1	
23	E3745	Inlet rocker box	1	
24	E3744	Exhaust rocker box	1	
25	E3743	Joint washer	2	
26	E3858	Rocker box stud ($\frac{1}{8}$ in. O.A.)	4	
27	E3302	Plain washer	4	
28	F879	Nut	4	
29	E3668	Screw ($\frac{1}{8}$ in. U.H.)	4	
30	E3857	Plain washer	4	
31	E3794	Cylinder head bolt (5 $\frac{7}{16}$ in. U.H.)	2	
32	E3795	Cylinder head torque stay bolt	2	
33	E3809	Oil feed bolt	2	
34	F1880	Copper washer	6	
35	E400	Domed nut	2	
36	E4610	Inspection cap	4	
37	E3751	Fibre washer	4	
38	E3749	ROCKER (right exhaust, left inlet)	2	
39	E3750	ROCKER (left exhaust, right inlet)	2	
40	E3222	Rocker ball pin	4	
41	E3223	Rocker adjusting pin	4	
42	GS662	Adjuster lock nut	4	
43	E1330	Thrust washer, $\frac{3}{8}$ in.	4	
44	E2534	Thrust washer, $\frac{7}{16}$ in.	6	
45	E3224	Spring washer	2	
46	E3748	Rocker spindle	2	
47	E3253	Sealing rubber	2	
48	E1335	Copper washer	2	
49	E1435	Domed nut	2	
50	E4008	Push rod	4	
51	E4751	Cover tube	2	
52	E4746	Bottom cup	2	
53	E4752	Rubber washer	4	
54	E4671	Locking spring	4	

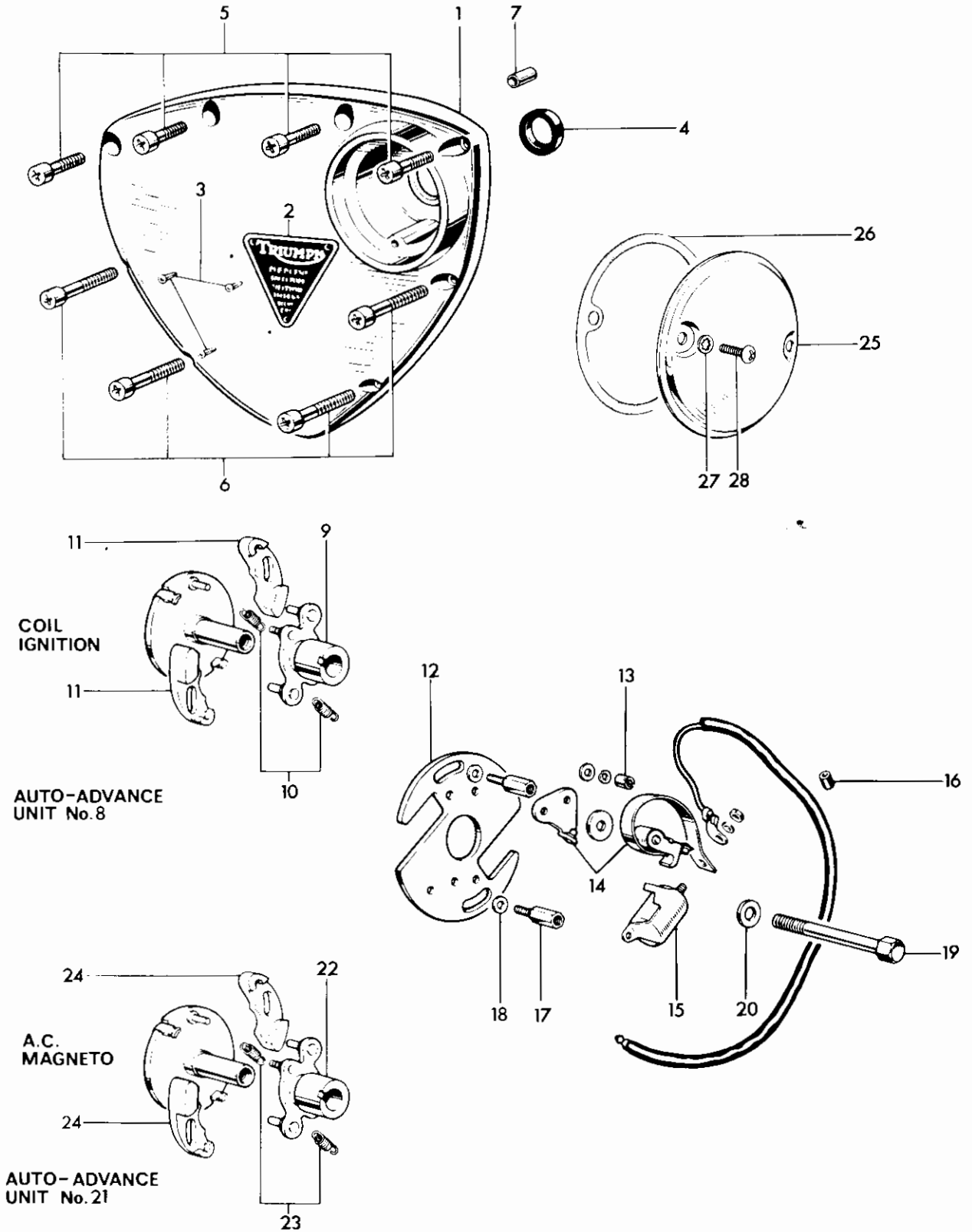

Fig. 8. TIMING COVER AND CONTACT BREAKER

TIMING COVER AND CONTACT BREAKER

1	E4630	Timing cover	1	
2	E4016	Patent plate	1	
3	D208-5	Hammer-drive screw	3	
4	E4568	Oil seal	1	
5	E3800	Screw ($\frac{7}{8}$ in. U.H.)	4	
6	E3801	Screw ($1\frac{1}{8}$ in. U.H.)	4	
7	T989	Hollow dowel	1	
8	54419254	AUTO-ADVANCE UNIT	1	} Coil Ignition models
9	Not supplied	Cam... ..	1	
10	54415642	Spring set	1	
11	42539	Weight	2	
12	425379	CONTACT BREAKER PLATE ASSEMBLY... ..	1	
13	169194	Slotted nut... ..	4	
14	54415803	Contact set	2	
15	425377	Condenser	2	
16	E4707	Rubber grommet	1	
17	E4747	Pillar bolt	2	
18	E6559	Washer	2	
19	E5451	Bolt (2 in. U.H.)	1	
20	S25-43	Washer	1	
21	54415746	AUTO-ADVANCE UNIT	1	} A.C. Ignition models
22	54415473	Cam... ..	1	
23	54415641	Spring set	1	
24	425359	Weight	2	
25	E4571	Cover	1	
26	E5049	Joint washer	1	
27	GS299	Serrated washer	2	
28	F4715	Screw ($15/32$ in. U.H.)	2	

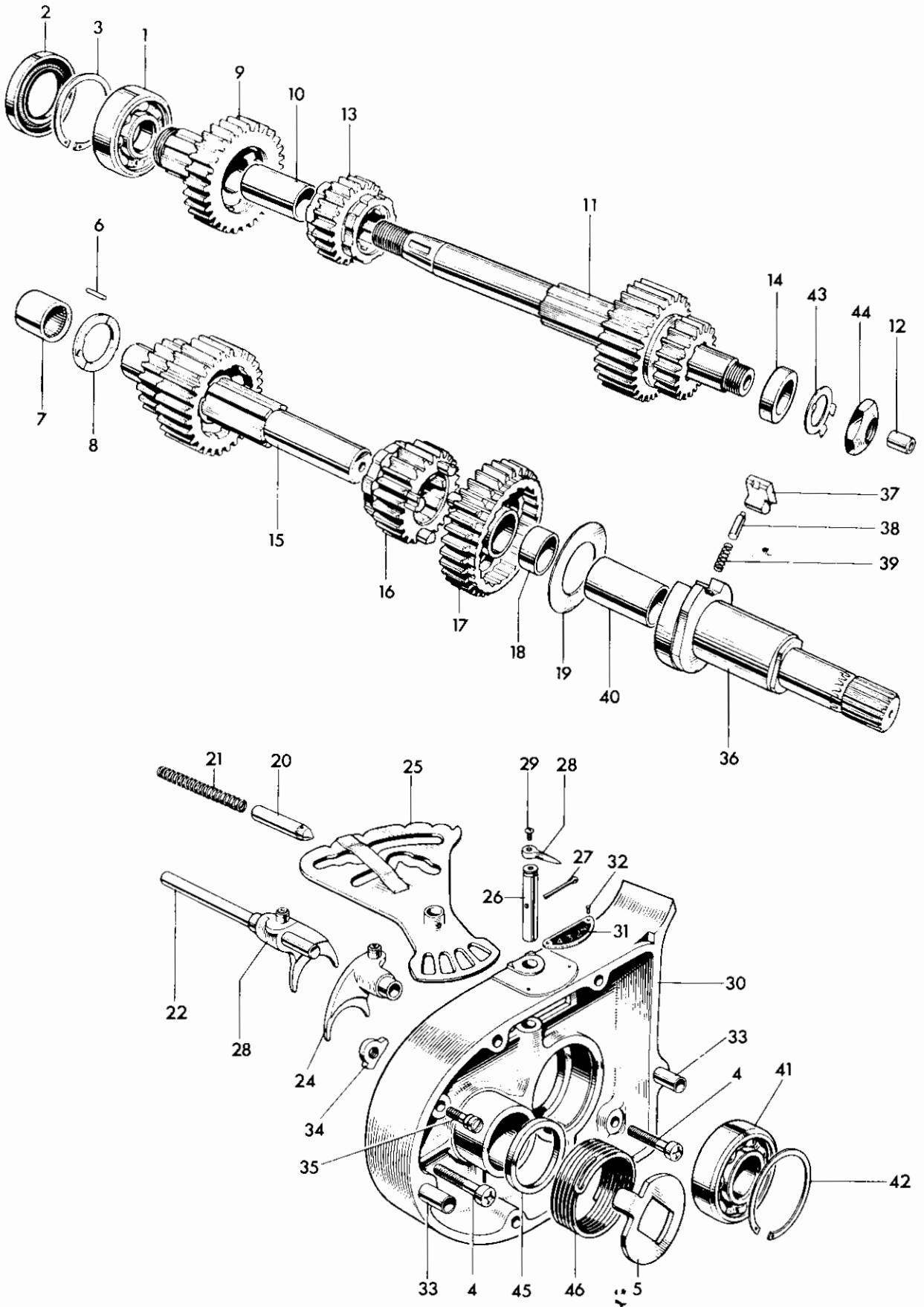

Fig. 9. GEARBOX SHAFTS, BEARINGS AND INNER COVER

GEARBOX SHAFTS, BEARINGS AND INNER COVER

1	T665	High gear bearing (ball journal)	1	
2	T1478	Oil seal	1	
3	W680	Circlip	1	
4	E3204	Screw (1 in. U.H.)	2	
5	T1422	Return spring plate	1	
6	T912	Peg	1	
7	T1606	Layshaft bearing	1	
8	T1607	Thrust washer	1	
9	T1947	MAINSHAFT HIGH GEAR (22T)	1	
10	T1405	High gear bush	1	
11	T2275	MAINSHAFT c/w THIRD AND LOW GEARS (16/24T)	1	
12	T1391	Clutch rod bush	1	
13	T1922	Mainshaft second gear (21T)	1	
14	T1411	Mainshaft distance piece	1	
15	T1949	Layshaft c/w second and high gears (15/23T)	1	
16	T1839	Layshaft third gear (20T)	1	
17	T1950	LAYSHAFT LOW GEAR (27T)	1	
18	T1393	Low gear bush	1	
19	T1426	Pawl retaining disc	1	
20	T1471	Camplate index plunger	1	
21	T373	Index plunger spring	1	
22	T1457	Selector fork spindle	1	
23	T1480	Mainshaft selector fork	1	
24	T1481	Layshaft selector fork	1	
25	T1768	Gear selector camplate	1	
26	T1418	Camplate spindle	1	
27	$\frac{1}{8}$ in. x $\frac{3}{4}$ in.	Split pin	1	
28	T1416	Gear indicator pointer	1	
29	H688	Screw ($\frac{5}{16}$ in. U.H.)	1	
30	T1448	Inner cover	1	
31	T417	Gear indicator plate	1	
32	D208-5	Indicator plate rivet	2	
33	T1440	Hollow dowel	2	
34	T1157	Kickstarter stop plate	1	
35	T1390	Stop plate and anchor screw	1	
36	T1981	KICKSTARTER SPINDLE	1	
37	T1431	Kickstarter pawl	1	
38	T1282	Plunger	1	
39	T1161	Plunger spring	1	
40	T1897	Bearing	1	
41	T1469	Mainshaft bearing (Ball journal)	1	
42	T280	Circlip	1	
43	T732	Tab washer	1	
44	S594	Mainshaft nut	1	
45	T1464	Distance piece	1	
46	T1441	Kickstarter return spring	1	

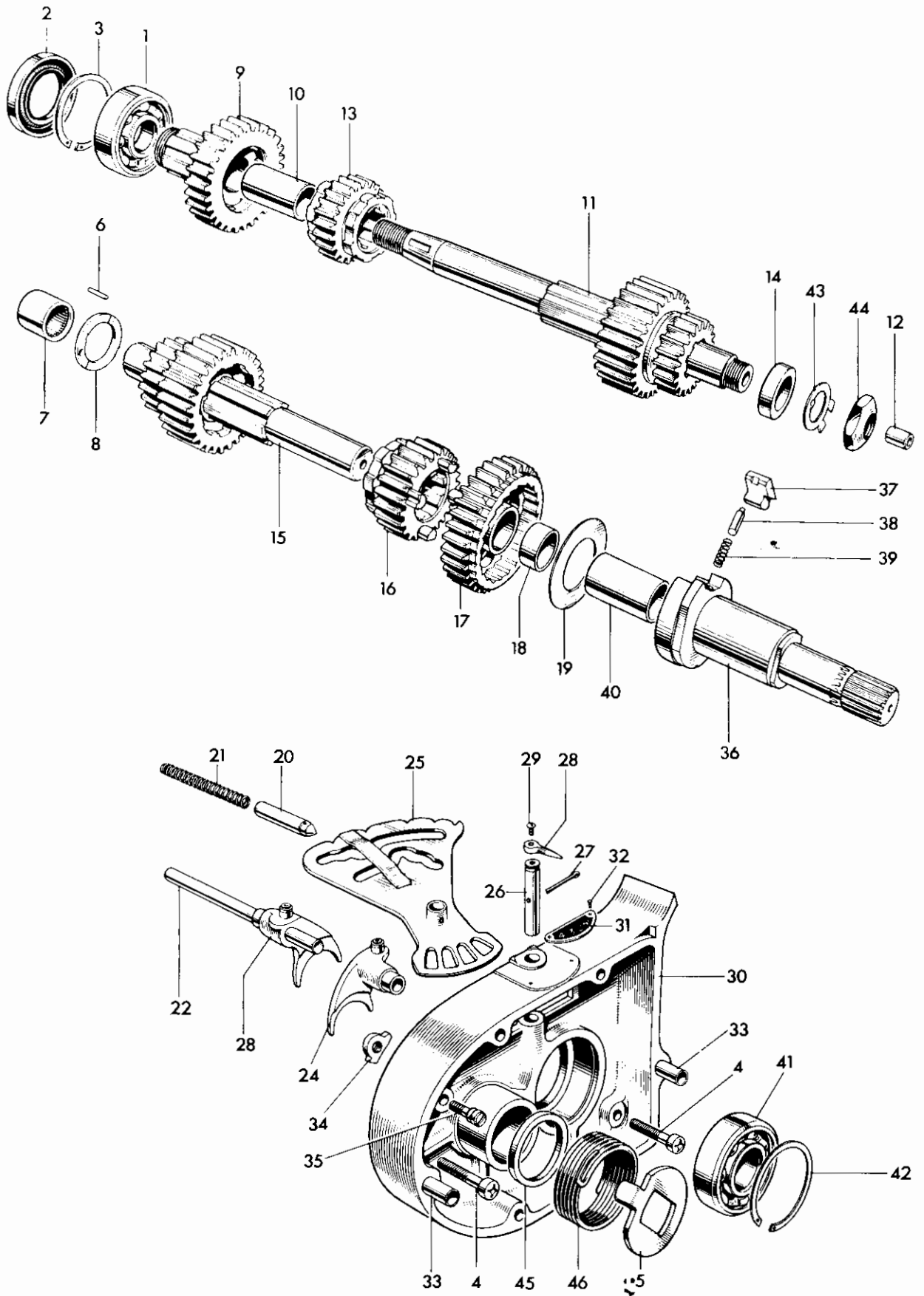

Fig. 9. GEARBOX SHAFTS, BEARINGS AND INNER COVER

Ref. No.	Part No.	DESCRIPTION	QUANTITY	REMARKS
----------	----------	-------------	----------	---------

WIDE RATIO GEARS
(Can be fitted to T90 or T100)

9	T1684	MAINSHAFT HIGH GEAR (23T)	1	
11	T2277	MAINSHAFT c/w THIRD & LOW GEAR (15/24T)	1	
13	T1837	Mainshaft second gear (20T)	1	
15	T1960	Layshaft c/w second & high gear (14/24T)	1	
16	T1839	Layshaft third gear (20T)	1	
17	T1961	LAYSHAFT LOW GEAR (29T)	1	

CLOSE RATIO GEARS
(Can be fitted to T90 or T100)

9	T1821	MAINSHAFT HIGH GEAR (20T)	1	
11	T2276	MAINSHAFT c/w THIRD & LOW GEAR (16/22T)	1	
13	T1832	Mainshaft second gear (20T)	1	
15	T1972	Layshaft c/w second and high gear (17/23T)	1	
16	T1842	Layshaft third gear (21T)	1	
17	T1950	LAYSHAFT LOW GEAR (27T)	1	

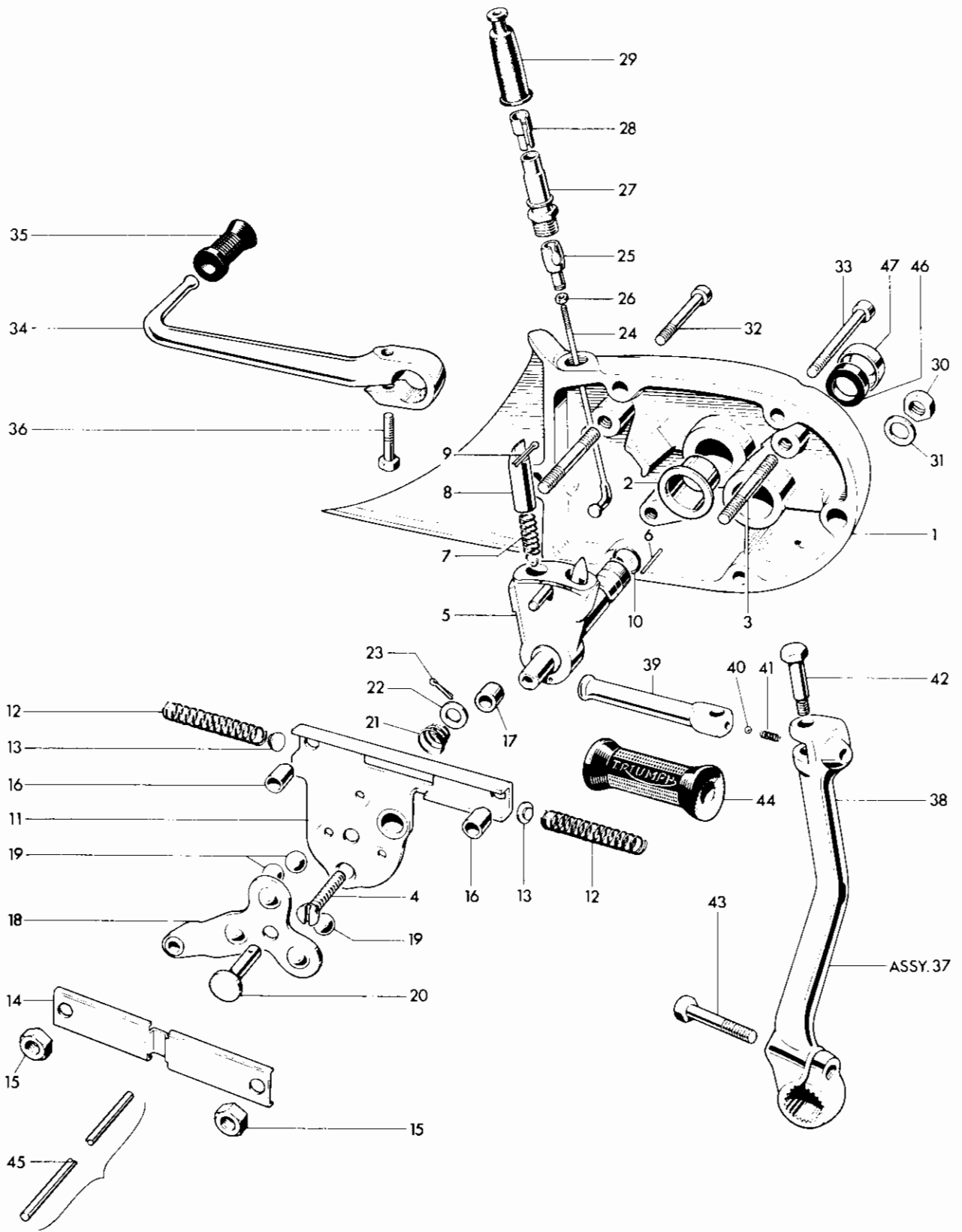

Fig. 10. GEARBOX OUTER COVER AND LEVERS

Ref. No.	Part No.	DESCRIPTION	QUANTITY	REMARKS
GEARBOX OUTER COVER AND LEVERS				
1	T1870	GEARBOX OUTER COVER	1	
2	T1395	Gearchange spindle bush...	1	
3	T1944	Stud (1 $\frac{3}{8}$ in. O.A.)	2	
4	T1875	Screw ($\frac{7}{8}$ in. O.A.)	1	
5	T1942	GEARCHANGE QUADRANT	1	
6	T1474	Spring retaining pin	2	
7	T1436	Plunger spring	2	
8	T1396	Selector plunger	2	
9	5/64 in. x $\frac{5}{8}$ in.	Split pin	2	
10	E3309	Sealing ring	1	
11	T1871	Return spring housing	1	
12	T1877	Return spring	2	
13	T1878	Thrust button	2	
14	T1977	Cover	1	
15	W103	Nut	3	
16	T1876	Distance piece	2	
17	T1874	Distance piece	1	
18	T1880	Clutch lever	1	
19	T1771	Ball, $\frac{3}{8}$ in. diam.	3	
20	T1710	Shaft	1	
21	T1712	Spring	1	
22	GS127	Plain washer	1	
23	5/64 in. x $\frac{1}{2}$ in.	Split pin	1	
24	T1945	Spoke	1	
25	T1946	Connector	1	
26	T1937	Nut	1	
27	T1644	Abutment	1	
28	T2062	Adaptor, short	As required	
28	T2063	Adaptor, long (For cable with short outer cover)...	As required	
29	T1646	Rubber cover	1	
30	S1-51	Nut	2	
31	S25-3	Plain washer	2	
32	T1401	Screw (2 $\frac{3}{8}$ in. U.H.)	2	
33	T1402	Screw (2 $\frac{3}{8}$ in. U.H.)	2	
34	T1435	Gearchange lever	1	
35	T449	Pedal rubber	1	
36	W932	Bolt (1 in. U.H.)	1	
37	T1677	KICKSTARTER LEVER COMPLETE...	1	
38	T1678	Kickstarter crank	1	
39	T1272	Kickstarter pedal	1	
40	S70-3	Steel ball ($\frac{1}{4}$ in. diam.)	1	
41	T1167	Index spring	1	
42	T1273	Pivot bolt	1	
43	T1439	Clamp bolt (1 $\frac{7}{8}$ in. U.H.)	1	
44	F1814	Pedal rubber	1	
45	T1970	Clutch operating rod	1	T90, T100
46	T2239	Oil seal	1	
47	T2238	Oil seal cover	1	

CLUTCH ASSEMBLY № 1

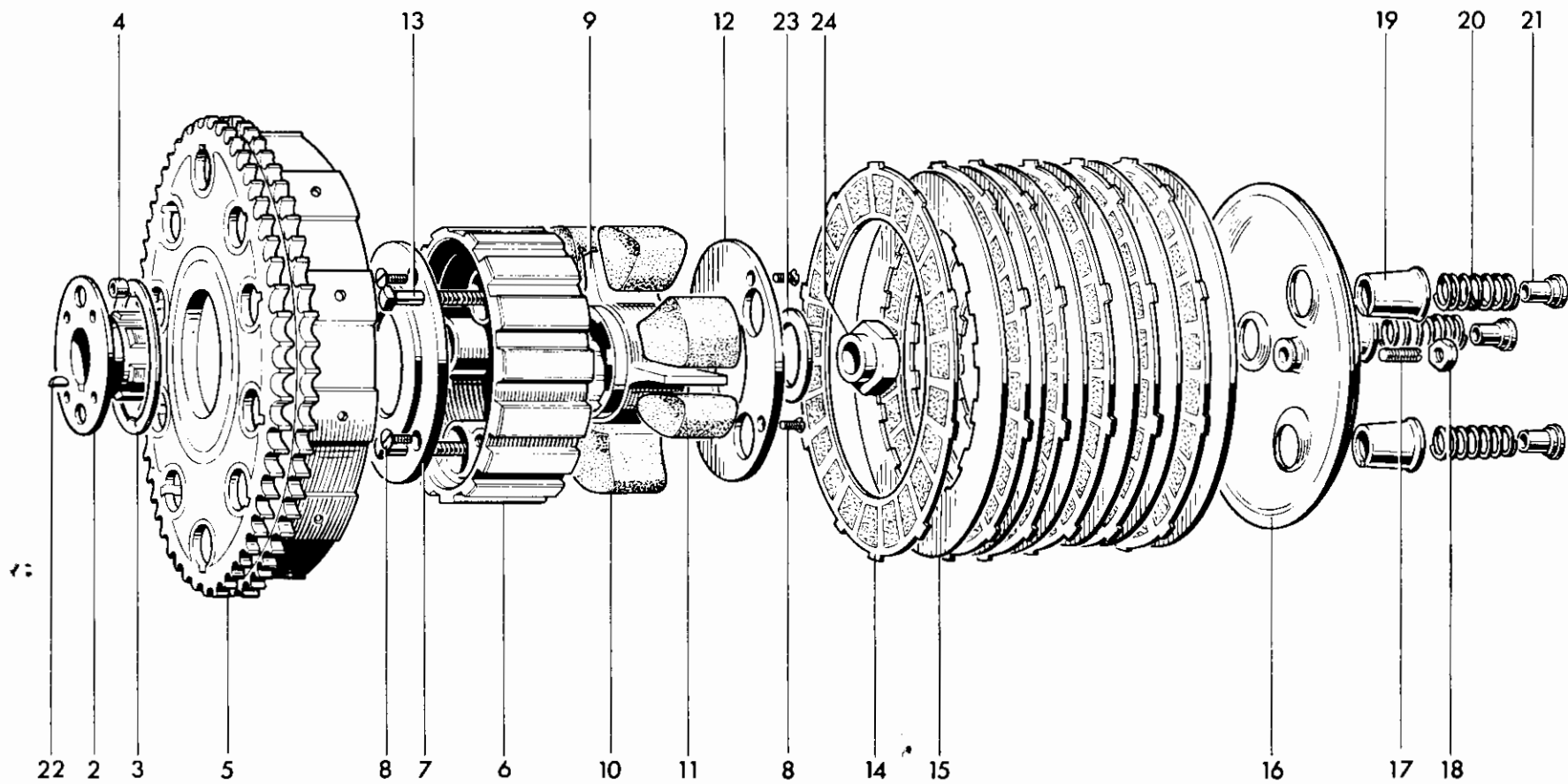

Fig. 11. CLUTCH

Ref. No.	Part No.	DESCRIPTION	QUANTITY	REMARKS
		CLUTCH		
1	T1935	CLUTCH COMPLETE	1	
2	T1751	Hub	1	
3	T1735	Thrust washer	1	
4	T394	Roller	20	
5	T1570	Sprocket and housing	1	
6	T1719	Centre (Shock absorber body)	1	
7	T1720	Inner plate	1	
8	T1040	Countersunk screw (0.417 in. U.H.)	6	
9	T1721	Shock absorber spider	1	
10	T1722	Drive rubber (large)	3	
11	T1723	Rebound rubber (small)	3	
12	T1724	Outer plate	1	
13	T423A	Screwed pin (1 27/32 in. U.H.)	3	
14	T1362	Driving plate (bonded)	5	
15	T1363	Driven plate (plain)	5	
16	T2156	Pressure plate	1	
17	T2159	Adjuster pin	1	
18	13206/00/1	Nut	1	
19	T1931	Spring cup	3	
20	T1560	Spring	3	
21	T427	Brass nut	3	
22	S66-1	Key	1	
23	T2279	Washer	1	
24	S586	Nut	1	

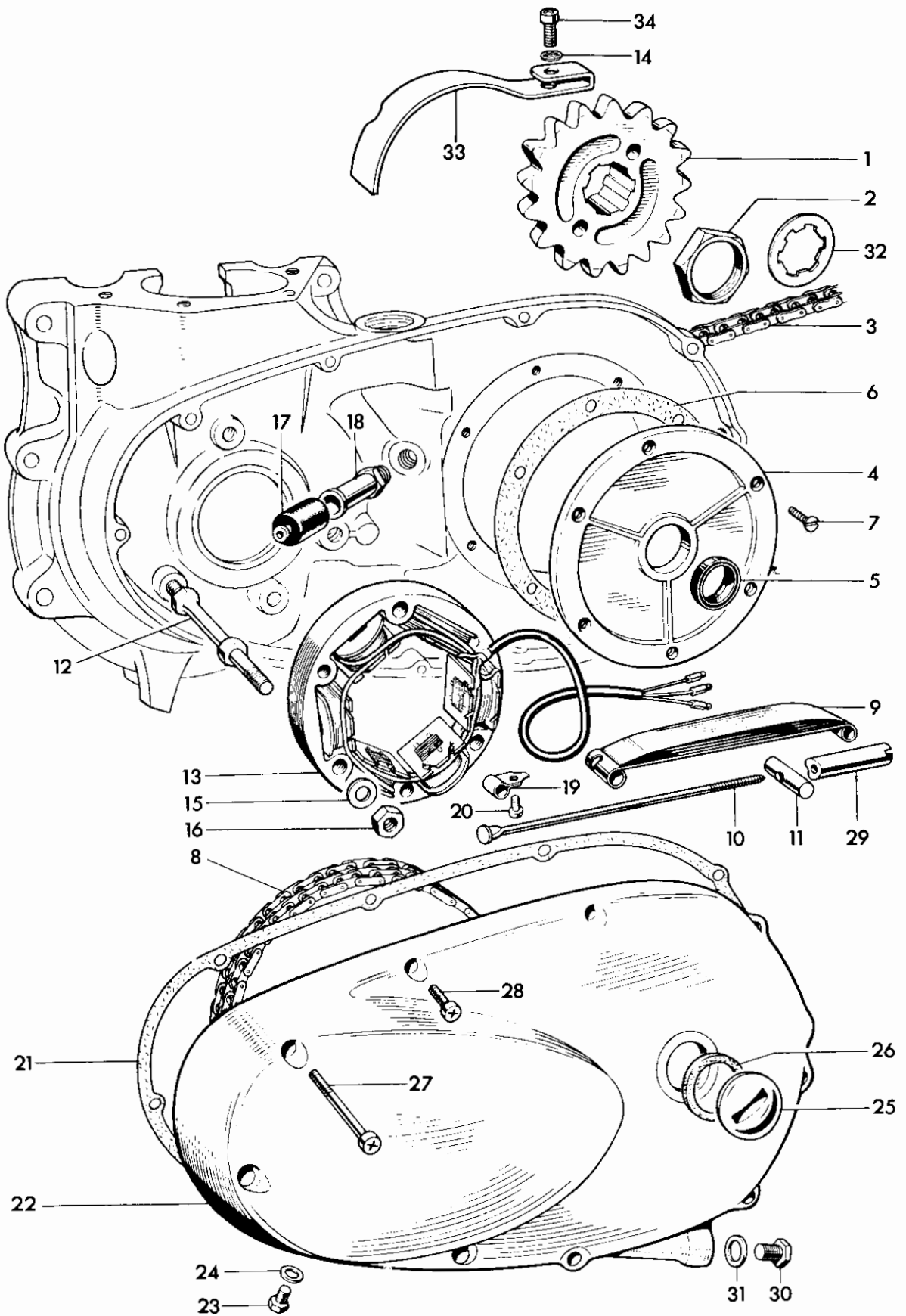

Fig. 12. CHAINCASE AND CHAINS

Ref. No.	Part No.	DESCRIPTION	QUANTITY	REMARKS
CHAINCASE AND CHAINS				
1	T1558	Gearbox sprocket (17 teeth)	1	T90
1	T1476	Gearbox sprocket (18 teeth)	1	T100S, T100C, T100T
1	T1476/19	Gearbox sprocket (19 teeth)	1	T100R
1	T1569	Gearbox sprocket (20 teeth)	1	
2	T1434	Gearbox sprocket nut	1	
3	D444	Rear chain, $\frac{5}{8}$ in. x $\frac{3}{8}$ in. x 102L	1	
3	D481	Rear chain, $\frac{5}{8}$ in. x $\frac{3}{8}$ in. x 103L	1	
4	E3789	Cover plate	1	
5	E3833	Oil seal	1	
6	E3832	Joint washer	1	
7	E3821	Countersunk screw ($\frac{5}{16}$ in. U.H.)	6	
8	D358	Primary chain, $\frac{3}{8}$ in. Duplex 78L	1	
9	E6283	Chain tensioner blade	1	
10	E4152	Tie rod	1	
11	E5977	Trunnion	1	
12	E6611	Stud ($3\frac{5}{8}$ in. O.A.)	3	
13	47162	Stator, RM 19	1	Coil Ignition
13	47188	Stator, R.M.19	1	A.C. Ignition
14	E1612	Serrated washer	1	
15	S25-3	Plain washer	3	
16	E5324	Nut	3	
17	E4144	Rubber grommet	1	
18	E5872	Sleeve nut	1	
19	E1509	Clip	1	
20	T361	Bolt ($\frac{1}{4}$ in. U.H.)	1	
21	E4156	Joint washer	1	
22	E4122	Chaincase	1	
23	DS57	Drain and level plug	1	
24	E2441	Copper washer	2	
25	E732	Filler plug	1	
26	NE507	Fibre washer	1	
27	E3802	Screw ($2\frac{3}{4}$ in. U.H.)	3	
28	E3668	Screw ($1\frac{5}{8}$ in. U.H.)	7	
29	E4153	Adjuster sleeve nut	1	
30	E4154	Drain plug	1	
31	T1738	Fibre washer	1	
32	T2056	Tab washer	1	
33	E6186	Crankcase protector	1	T100S, T100C, T100R, T100T
34	T1553	Screw ($\frac{3}{8}$ in. U.H.)	1	

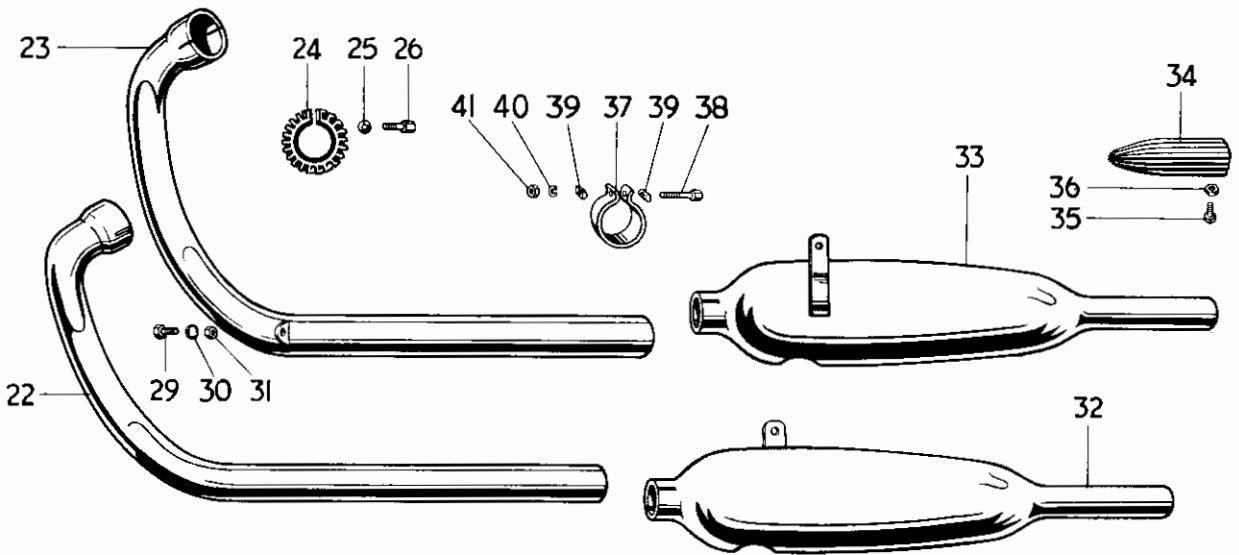
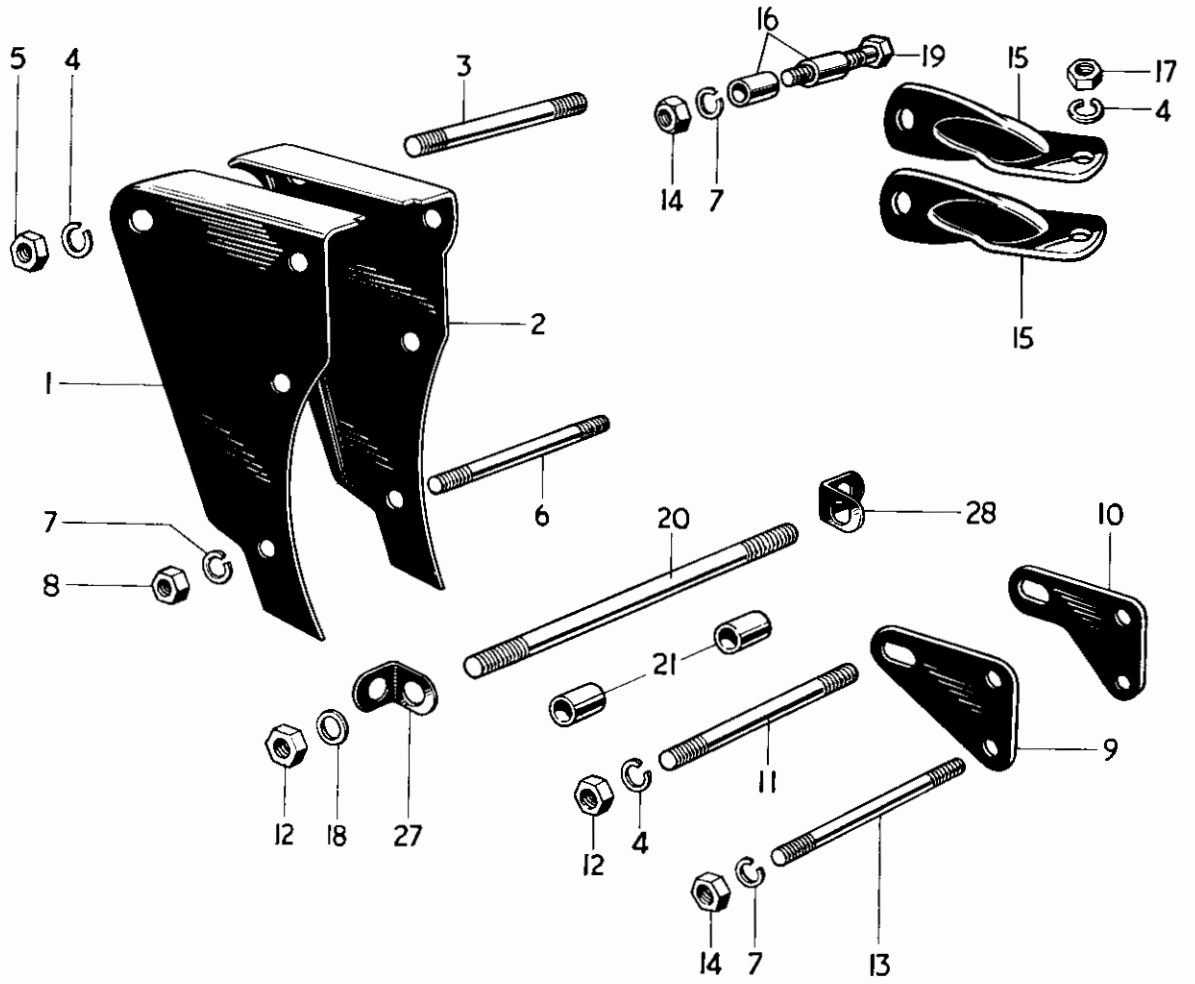

Fig. 13. ENGINE FITTINGS AND EXHAUST SYSTEM

Ref. No.	Part No.	DESCRIPTION	QUANTITY	REMARKS
ENGINE FITTINGS AND EXHAUST SYSTEM				
1	F7335	Left front engine plate...	1	
2	F7334	Right front engine plate	1	
3	F2825	Stud (3½ in. O.A.)	1	
4	S26-1	Spring washer	8	
5	PO172A	Nut	2	
6	E3804	Stud (3 in. O.A.)	3	
7	S26-3	Spring washer	8	
8	S1-51	Nut	3	
9	F4229	Left rear engine plate	1	
10	F4230	Right rear engine plate	1	
11	E3665	Stud (4½ in. O.A.)	1	
12	PO172A	Nut	4	
13	E3695	Stud (4⅞ in. O.A.)	2	
14	S1-51	Nut	5	
15	E4778	Torque stay	2	
16	E5072	Distance piece	2	
17	S1-52	Nut	2	
18	F5532	Plain washer	2	
19	E4165	Bolt (1⅞ in. U.H.)	1	
20	E3812	Stud (7⅞ in. O.A.)	1	
21	F4197	Distance piece	2	
22	E3992	Left exhaust pipe	1	T100
23	E3994	Right exhaust pipe	1	T100
22	E5325	Left exhaust pipe	1	T90, T100R, T100T
23	E5327	Right exhaust pipe	1	T90, T100R, T100T
24	E4947	Finned clip	2	
25	E410A	Hemispherical washer	2	
26	E409	Bolt (1⅞ in. U.H.)	2	
27	F4707	Left bracket	1	
28	F4283	Right bracket	1	
29	DS57	Bolt (⅞ in. U.H.)	2	
30	E1612	Serrated washer	2	
31	F879	Nut	2	
32	E3935	Left silencer	1	
32	E4157	Left muffler	1	T100R
33	E3936	Right silencer	1	
33	E4158	Right muffler	1	T100R
34	E4155	Silencer mute	As required	
35	H689	Screw (¼ in. U.H.)	As required	
36	H691	Nut	As required	
37	E2271	Clip	2	
38	F3430	Bolt (1¾ in. U.H.)	2	
39	E3768	"D" washer	4	
40	S26-3	Spring washer	2	
41	E1310	Nut	2	

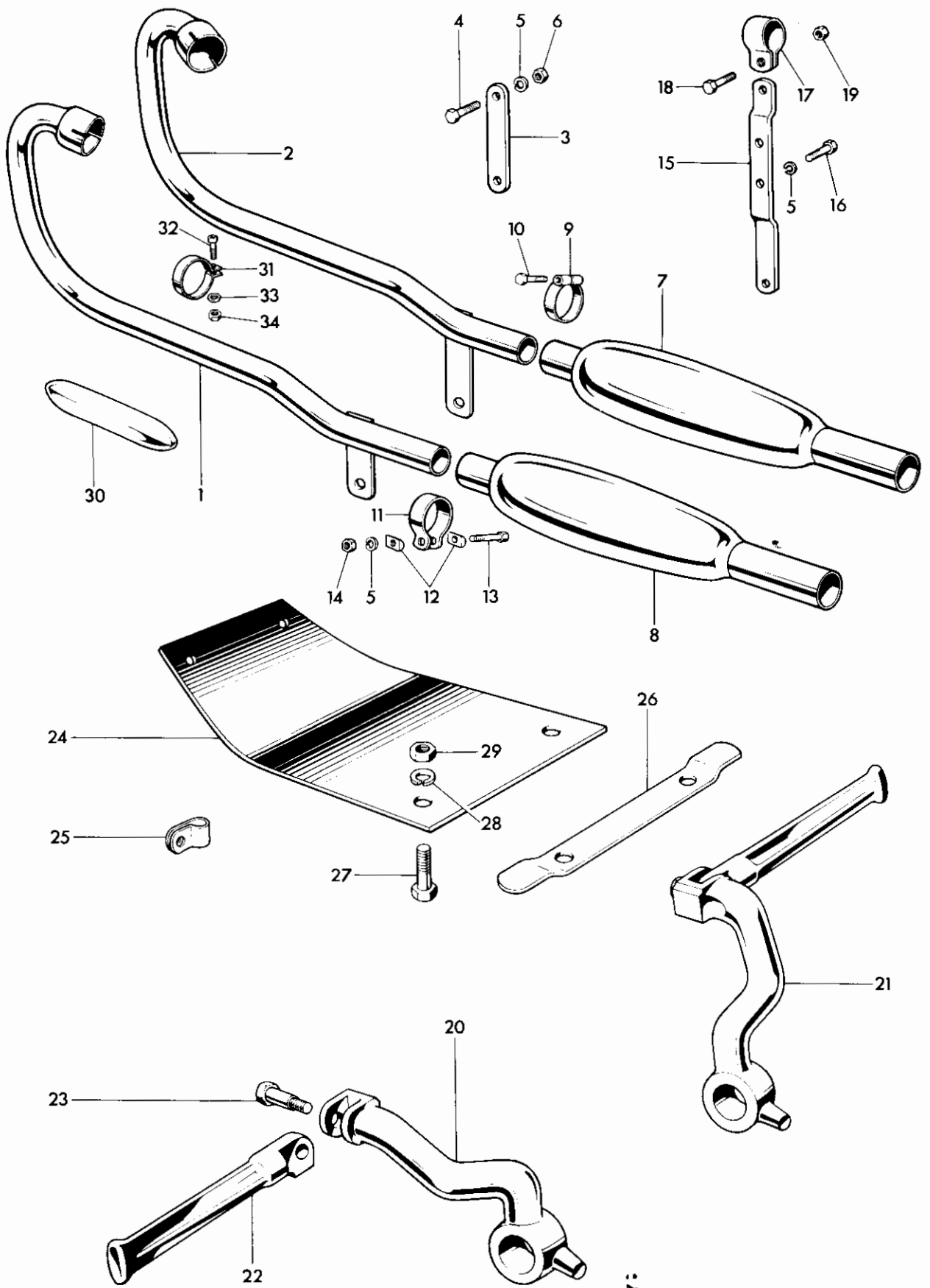

Fig. 14. EXHAUST PIPES, UNDERSHIELD AND FOOTPEGS (T100C)

EXHAUST PIPES, UNDERSHIELD AND FOOTPEG (T100C)

1	E7020	Left (lower) exhaust pipe	1	
2	E7022	Right (upper) exhaust pipe	1	
3	E6981	Stay	1	
4	11105/06/2	Bolt	1	
5	S26-3	Spring washer	4	
6	15105/00/2	Self locking nut	1	
7	E6974	Upper muffler	1	
8	E6975	Lower muffler	1	
9	E7299	Silencer clip	1	
10	11105/08/2	Bolt	1	
11	E5874	Silencer clip	1	
12	E3768	"D" washer	2	
13	F3430	Bolt (1 $\frac{3}{4}$ in. U.H.)	1	
14	E1310	Nut	1	
15	E6982	Bracket	1	
16	H590	Bolt ($\frac{7}{8}$ in. U.H.)	2	
17	F7550	Clip	1	
18	F2335	Bolt ($\frac{1}{8}$ in. U.H.)	1	
19	S1-51	Nut	1	
20	F7018	LEFT FOLDING FOOTPEG	1	
21	F7019	RIGHT FOLDING FOOTPEG	1	
22	F6411	Pedal	2	
23	F6655	Pivot bolt	2	
24	F7390	Undershield	1	
25	F1700	Clip, undershield	2	
26	F3078	Bracket	1	
27	F1369	Bolt ($\frac{5}{8}$ in. U.H.)	4	
28	S26-2	Washer	4	
29	F879	Nut	4	
30	E4204	Exhaust pipe guard	2	
31	E4207	Clip	4	
32	F4715	Screw ($\frac{1}{32}$ in. U.H.)	4	
33	E2351	Washer	4	
34	F3799	Nut	4	

Ref. No.	Part No.	DESCRIPTION	QUANTITY	REMARKS
		FRAME		
1	F7312	Front frame	1	
2	H111	Steering race cup	2	
3	S70-3	Steel ball ($\frac{1}{2}$ in. dia.)	40	
4	H1018	Top cone and dust cover	1	
5	F5679	Washer	2	
6	F7155	Steering stops	2	
7	F7313	Rear frame	1	
8	F2842	Stud ($4\frac{3}{8}$ in. O.A.)	1	
9	S26-1	Spring washer	2	
10	S1-52	Nut	2	
11	S583	Bolt	2	
12	PCW73A	Spring washer	2	
13	F7693	Centre stand	1	T100R
13	F7692	Centre stand	1	
14	T449	Pedal rubber	1	
15	F5678	Pivot bolt	2	
16	F4484	Tab washer	2	
17	F2725	Nut	2	
18	F3617	Return spring	1	
19	F7373	Prop stand	1	
19	F7356	Prop stand	1	T100C, T100R
20	F7021	Pivot bolt	1	
21	15106/00/2	Self locking nut	1	
22	F2610	Return spring	1	
23	F4214	Left footrest	1	
24	F4215	Right footrest	1	
25	NF704	Pedal rubber	2	
26	F4369	Bolt ($2\frac{1}{8}$ in. U.H.)	2	
27	F4370	Plain washer	2	
28	DS47	Nut	2	
29	F5087	Left pillion footrest support	1	
30	F5088	Right pillion footrest support	1	
31	DS58	Bolt ($\frac{3}{8}$ in. U.H.)	4	
32	S26-3	Spring washer	4	
33	F7705	Pedal stop screw	1	
34	13105/00/2	Nut	2	
35	F5552	PILLION FOOTREST	2	
36	F2268	Footrest hanger	2	
37	F5535	Bolt ($\frac{13}{16}$ in. U.H.)	2	
38	S26-1	Spring washer	2	
39	F1694	Pedal	2	
40	F2271	Pivot bolt	2	
41	F2277	Spring washer	2	
42	S1-S1	Nut	6	
43	F1695	Pedal rubber	2	
44	F7706	Brake pedal spindle	1	
45	SCZ45	Spring washer	1	
46	13208/00/2	Nut	1	
47	F7703	Brake pedal	1	
48	S26-16	Spring washer	1	
49	S25-2	Plain washer	1	
50	13206/00/2	Nut	1	

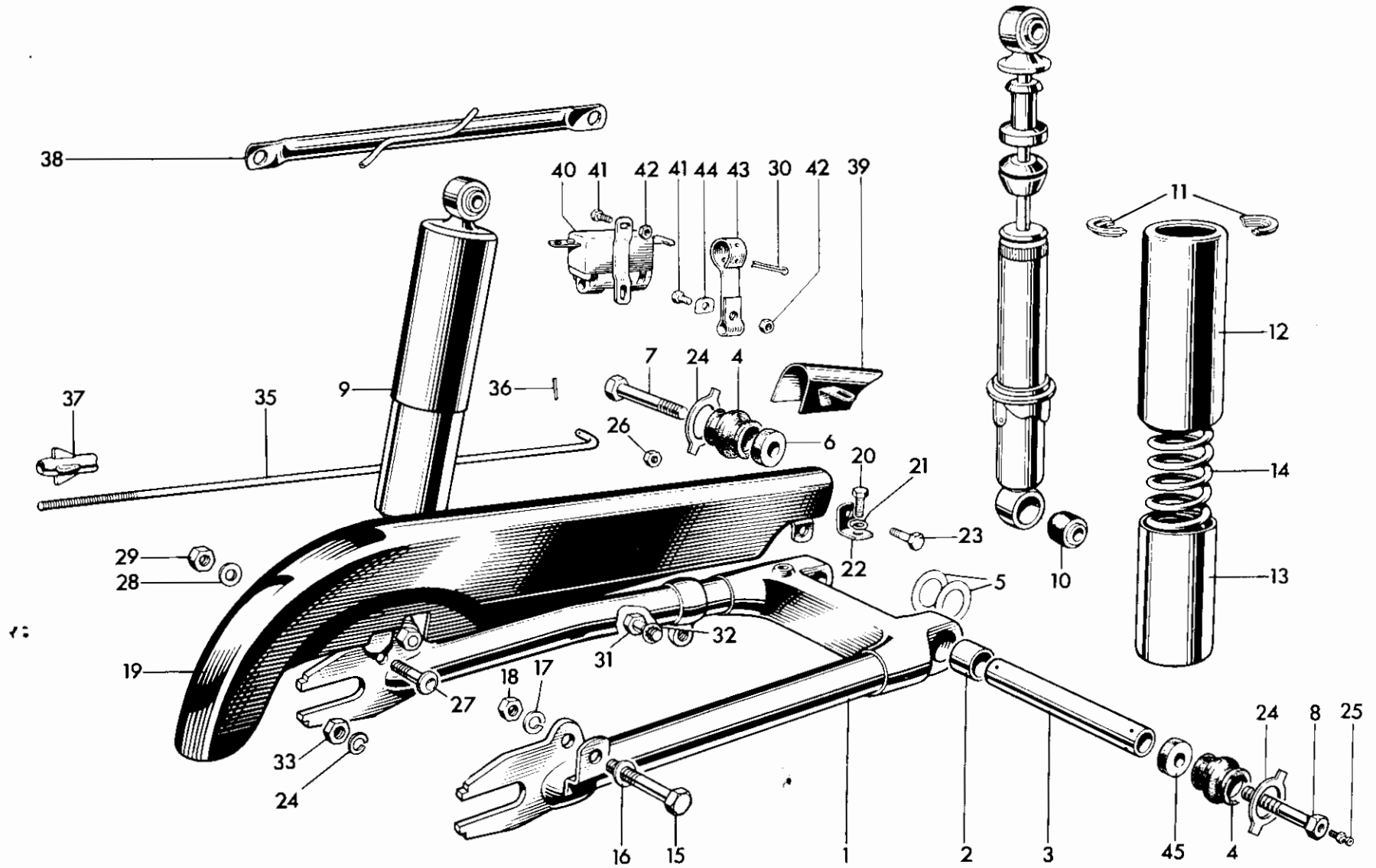

Fig. 16. SWINGING FORK, SUSPENSION UNITS AND CHAINGUARD

Ref. No.	Part No.	DESCRIPTION	QUANTITY	REMARKS
SWINGING FORK, SUSPENSION UNITS AND CHAINGUARD				
1	F7375	SWINGING FORK	1	
2	F4076	Pivot bush	2	
3	F7342	Spindle	1	
4	F7270	Gaiter	2	
5	F4385	Shim 0.003 in.	as required	
5	F4386	Shim 0.005 in.	as required	
6	F7344	Left distance piece	1	
7	S579	Left bolt	1	
8	S580	Right bolt	1	
9	64053946	SUSPENSION UNIT	2	
9	64054164	SUSPENSION UNIT	2	T 100C, T100R
10	9054/316A	Bonded bush	4	
11	9054/171	Spring retainer	4	
12	9054/151	Outer dirt shield	2	
13	9054/47	Inner dirt shield	2	
14	64539963	Spring, 130 lbs. Red/Orange	2	
14	90S4/277	Spring, 110 lbs. Red/Red	as required	
14	SA253/5	Spring, 145 lbs. Blue/Yellow	as required	
15	E2113	Unit fixing bolt (1 $\frac{1}{8}$ in. U.H.)	4	
16	F2184	Plain washer	2	
17	S26-1	Spring washer	2	
18	PO172A	Nut	2	
19	F5409	Upper chainguard	1	
20	DS57	Bolt ($\frac{7}{8}$ in. U.H.)	1	
21	S26-2	Spring washer	1	
22	F4134	Front bracket	1	
23	H590	Bolt ($\frac{7}{8}$ in. U.H.)	1	
24	F7343	Tab washer	2	
25	NW100	Lubricator	1	
26	W1691	Self locking nut	1	
27	F4136	Stepped bolt	1	
28	S25-3	Plain washer	1	
29	S1-51	Nut	1	
30	$\frac{3}{32}$ in. x $\frac{7}{8}$ in.	Split pin	1	
31	S581	Bolt	1	
32	E2288	Serrated washer	1	
33	DS47	Nut	1	
34	PCW73A	Spring washer	1	
35	F7386	Brake operating rod	1	
36	$\frac{1}{8}$ in. x $\frac{3}{8}$ in.	Split pin	1	
37	F7387	Adjuster nut	1	
38	F7290	Brake torque stay	1	
39	F7707	Front chainguard	1	
40	31383	Stop lamp switch, type 22 B	1	
41	T1076	Bolt ($\frac{3}{8}$ in. U.H.)	3	
42	F4717	Self locking nut	5	
43	F5687	Lever	1	
44	F5413	'D' washer	1	
45	F7774	Right distance piece	1	

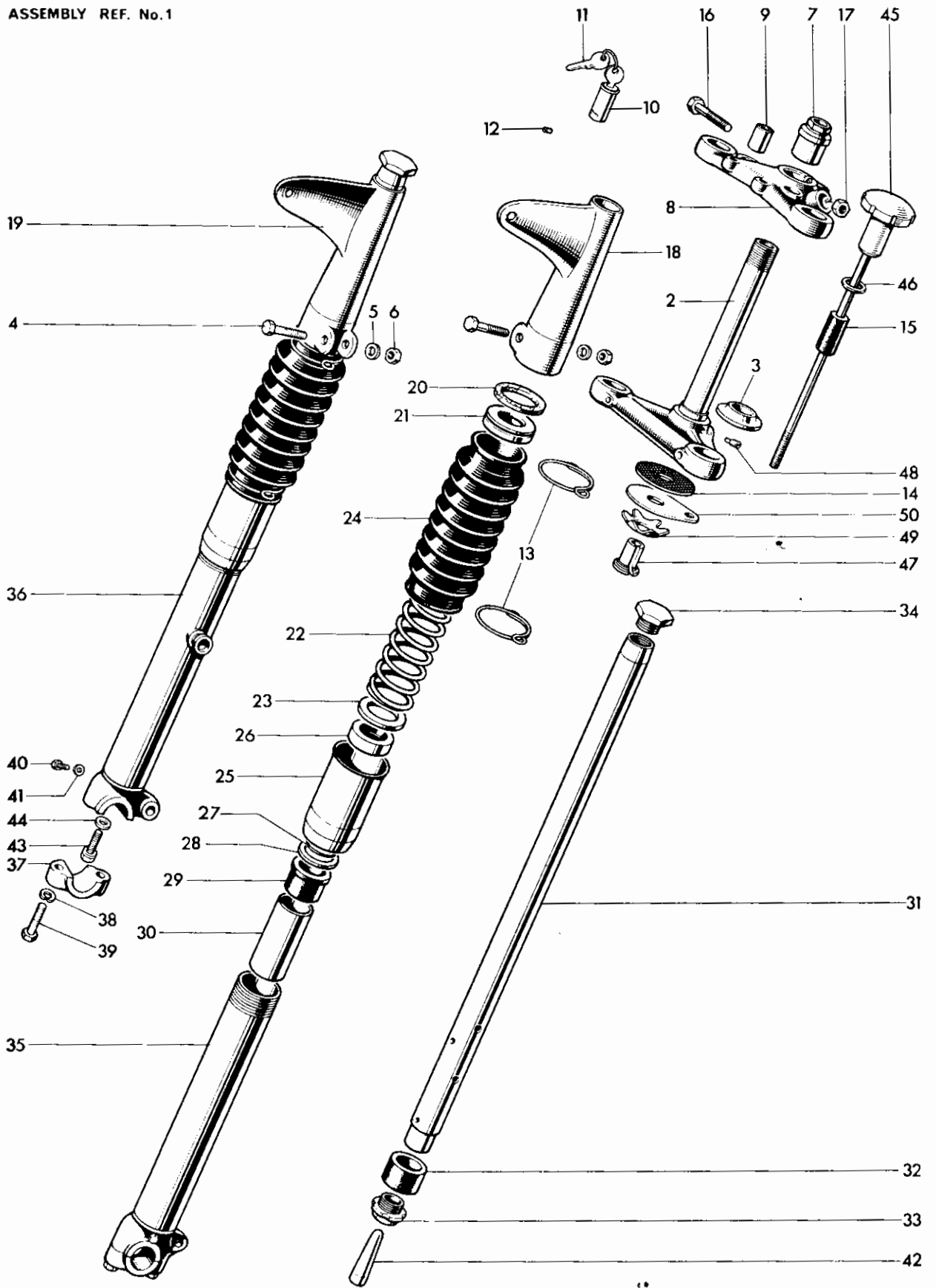

Fig. 17. TELESCOPIC FRONT FORK

TELESCOPIC FRONT FORK T90, T100S, T100T, T100R

1	H2111	FORK ASSEMBLY	1	
2	H2109	Middle lug and stem	1	
3	H439	Bottom cone ...	1	
4	H941	Pinch bolt (2½ in. U.H.)	2	
5	S25-2	Plain washer	2	
6	E2412	Nut ...	2	
7	H2108	Fork stem sleeve nut	1	
8	H2100	TOP LUG ASSEMBLY	2	
9	H1527	Bonded bush	2	
10	F6738	Lock c/w 2 keys	1	
11	—	Key (state serial number)	1	
12	S578	Grub screw	1	
13	H2083	Gaiter clip	4	
14	H435	Friction disc	1	
15	H1618	Rubber sleeve	1	
16	F1760	Pinch bolt (1 ⅞ in. U.H.)	1	
17	H379	Seated nut	1	
18	H1888	Left top cover	1	
19	H1887	Right top cover	1	
20	F4047	Cork washer	2	
21	H1657	Spring abutment	2	
22	H1891	Solo main spring (Yellow/Blue)	2	
23	H1656	Plain washer	2	
24	H1645	Telescopic gaiter	2	
25	H1654	DUST EXCLUDER SLEEVE NUT	2	
26	H1500	Oil seal	2	
27	H2119	"O" ring	2	
28	H431	Plain washer	2	
29	H441	Top bearing	2	
30	H1896	Damping sleeve	2	
31	H1889	STANCHION c/w BEARING	2	
32	H443	Lower bearing	2	
33	H1058	Bearing nut	2	
34	H1658	Cap nut	2	
35	H1842	LEFT BOTTOM MEMBER c/w CAP	1	
36	H1843	RIGHT BOTTOM MEMBER c/w CAP	1	
37	H1844	Spindle cap	2	
38	S26-3	Spring washer	4	
39	H1070	Cap bolt (1 ⅞ in. U.H.)	4	
40	H1071	Drain plug	2	
41	H430	Fibre washer	2	
42	H1499	Restrictor	2	
43	H1063	Flanged bolt (⅜ in. U.H.)	2	
44	H1062	Aluminium washer	2	
45	H1142	Steering damper rod c/w knob	1	
46	H565	Plain washer	1	
47	H408	Adjuster sleeve	1	
48	H2107	Locating pin	1	
49	H95	Spring plate	1	
50	H1797	Anchor plate	1	

FORK ASSEMBLY REF. Nº 1

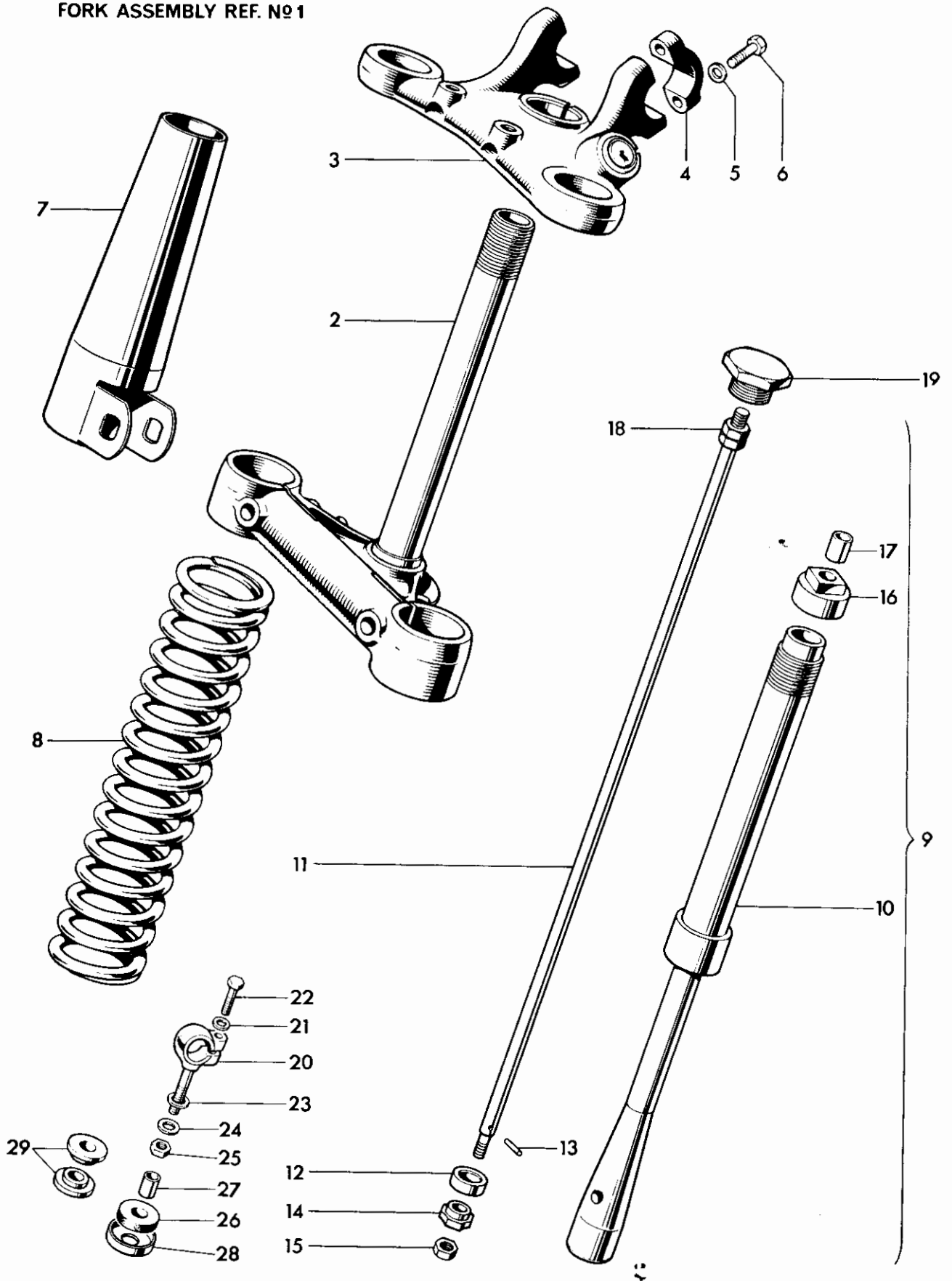

Fig. 18. TELESCOPIC FRONT FORK, U.S.A. T100C AND T100R

TELESCOPIC FRONT FORK, U.S.A. T100C AND T100R

1	H2113	FORK ASSEMBLY	1	T100R
1	H2112	FORK ASSEMBLY	1	T100C
2	H2110	Middle lug and stem...	1	
3	H2099	TOP LUG c/w CAPS AND LOCK	1	
4	H722	Cap	2	
5	S25-3	Plain washer	4	
6	S589	Bolt (1 $\frac{1}{8}$ in. U.H.)	4	
7	H1696	Top cover	As required	
8	H1892	Main spring (yellow green)	2	
9	H1913	DAMPER ASSEMBLY	2	
10	H1893	Restrictor body...	2	
11	H1897	Rod	2	
12	H1764	Cup	2	
13	H454	Pin	2	
14	H452	Oil restrictor	2	
15	F879	Nut	2	
16	H2102	Restrictor body cap c/w bush	2	
17	H2104	Bush	2	
18	7224	Nut	4	
19	H1762	Cap nut	2	

All other parts are as listed on Page 51

HANDLEBAR MOUNTINGS

20	H1523	Handlebar eyebolt	2	} T90, T100S, T100T
21	F1335	Plain washer	2	
22	H1340	Bolt (1 $\frac{1}{8}$ in. U.H.)	2	
23	H1708	Plain washer	2	
24	H1529	Hemispherical washer	2	
25	F3955	Self-locking nut	2	
26	H1580	Steady rubber	2	} As required
27	H1581	Distance piece	2	
28	F3814	Cup	2	
29	H1616	Solid bush (for handlebar-mounted windscreen)	as required	

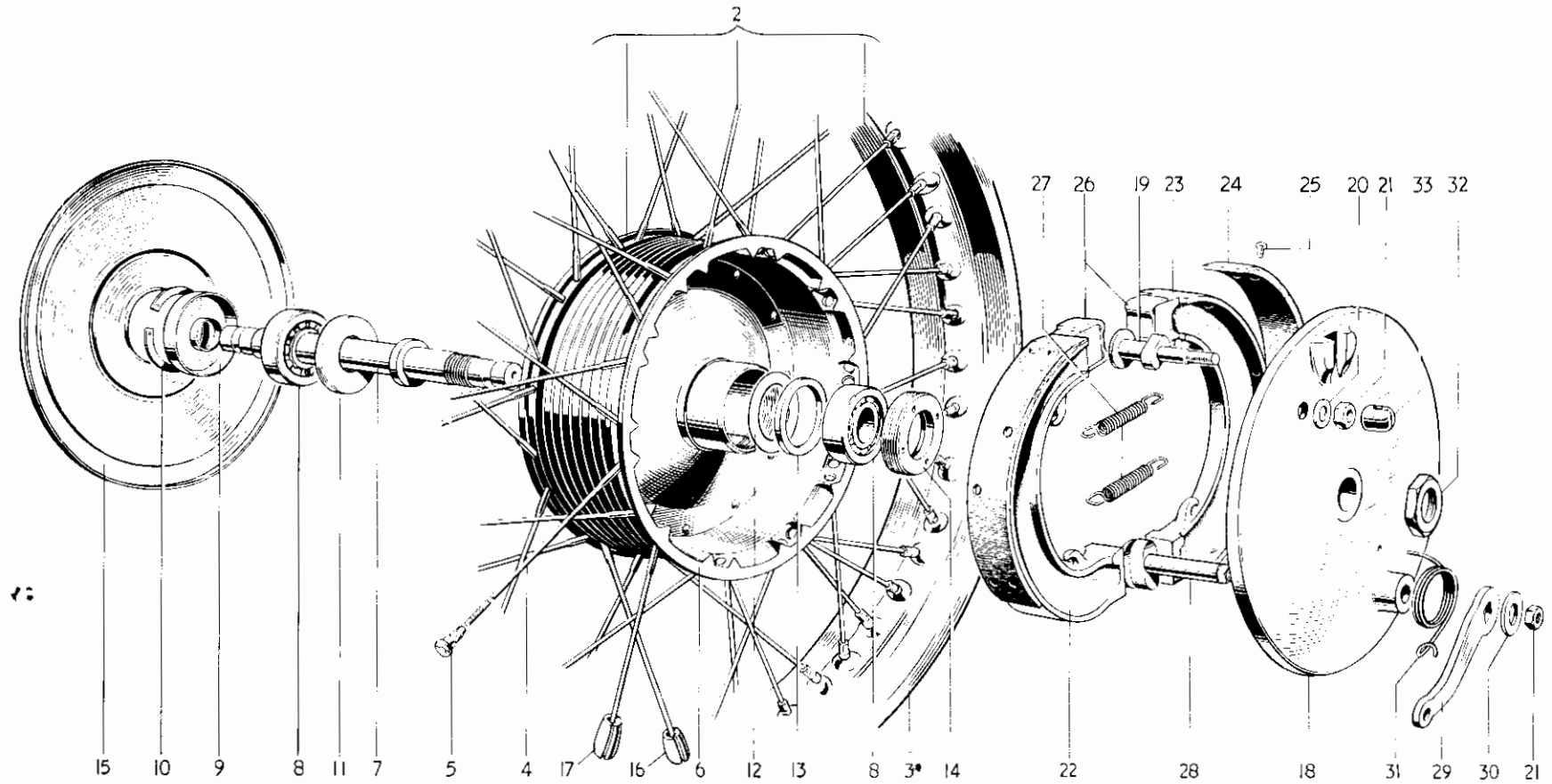

Fig. 19. FRONT WHEEL

Ref. No.	Part No.	DESCRIPTION	QUANTITY	REMARKS
		FRONT WHEEL		
1	W1665	FRONT WHEEL COMPLETE	1	T100R, T100C
1	W1664	FRONT WHEEL COMPLETE	1	
2	W1229	RIM, SPOKES AND HUB ASSEMBLY	1	T100R, T100C
2	W1370	RIM, SPOKES AND HUB ASSEMBLY	1	
3	W1230	Front wheel rim (WM2-19)	1	T100R, T100C
3	W1373	Front wheel rim (WM2-18)	1	
4	W1236	Spoke (8/10G x 6 in. straight) c/w nipple ...	40	T100R, T100C
4	W1497	Spoke (8/10G x 5 $\frac{5}{8}$ in. straight) c/w nipple ...	40	
5	S79-2	Spoke nipple	40	
6	W1231	Hub and brake drum	1	
7	W1641	Wheel spindle	1	
8	W653	Bearing	2	
9	W1237	Dust cover	1	
10	T280	Circlip	1	
11	W1481	Grease retainer	1	
12	W1474	Grease retainer (Brake side)	1	
13	W1238	Backing ring	1	
14	W582	Retaining ring	1	
15	W1334	Cover plate	1	
16	W1197	Balance weight, $\frac{1}{2}$ oz.		As required
17	W1198	Balance weight, 1 oz.		As required
18	W1301	Brake anchor plate	1	
19	W1639	Fulcrum pin	1	
20	S25-2	Plain washer	1	
21	S1-52	Nut	2	
22	W1406	LEADING BRAKE SHOE C/W LINING	1	
23	W1407	TRAILING BRAKE SHOE C/W LINING	1	
24	NW243	Brake lining	2	
25	W129	Brass rivet	16	
26	W1415	Thrust pad	2	
27	W135	Shoe return spring	2	
28	W1243	Brake cam	1	
29	W1331	Brake cam lever	1	
30	S25-6	Plain washer	1	
31	W592	Lever return spring	1	
32	W1246	Anchor plate nut	1	
33	W1640	Abutment ($\frac{9}{16}$ in. deep)		As required
33	W1711	Abutment ($\frac{13}{16}$ in. deep)		As required

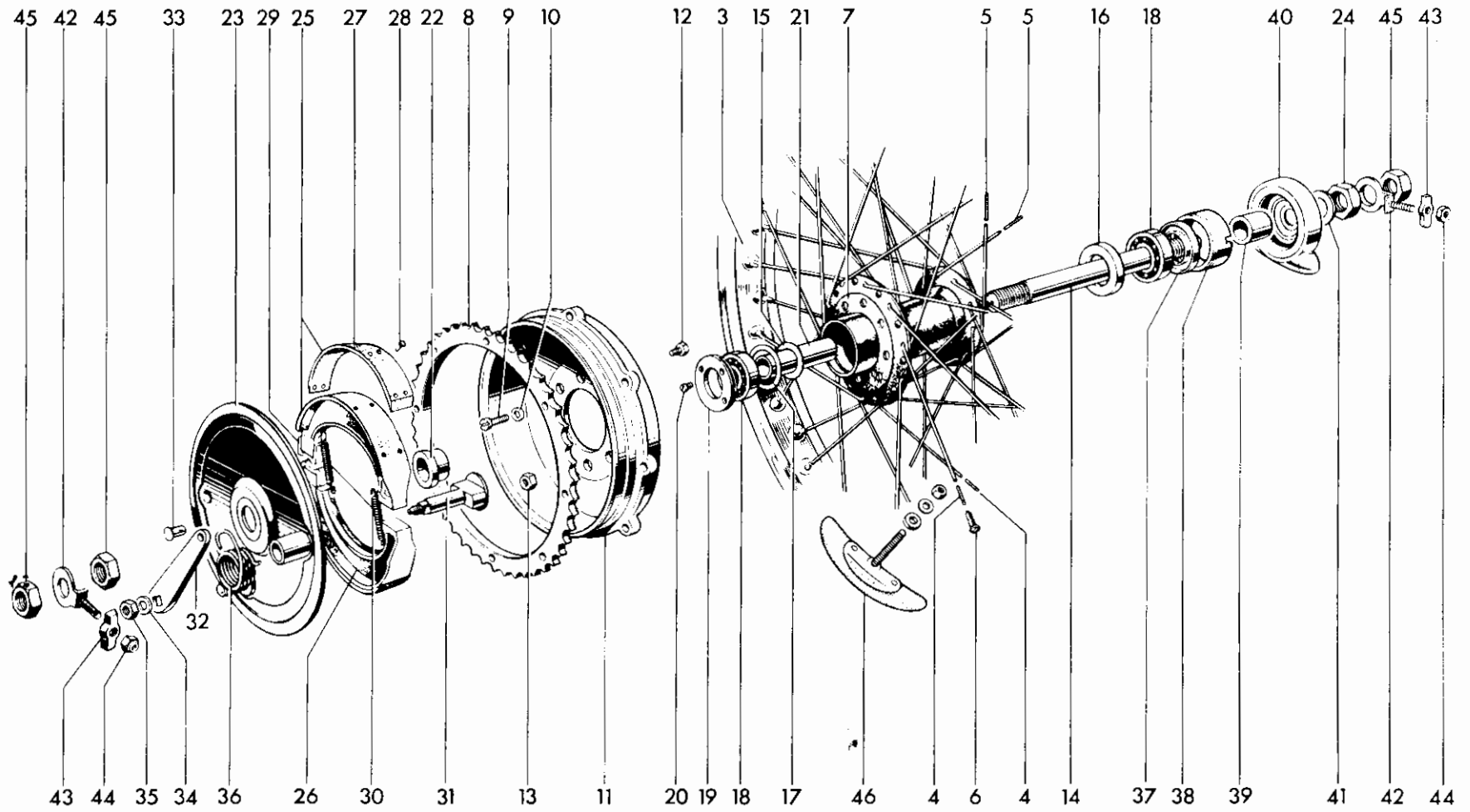

Fig. 20. REAR WHEEL

Ref. No.	Part No.	DESCRIPTION	QUANTITY	REMARKS
		REAR WHEEL		
1	W1741	REAR WHEEL COMPLETE	1	
1	W1742	REAR WHEEL COMPLETE	1	T100R, T100C
2	W1470	RIM, SPOKES AND HUB ASSEMBLY	1	
2	W1486	RIM, SPOKES AND HUB ASSEMBLY	1	T100R, T100C
3	W1471	Rear wheel rim WM2-18	1	
3	W1007	Rear wheel rim WM3-18	1	T100R, T100C
4	W1107	Spoke (8/10G x 7 $\frac{7}{8}$ in. 90°) c/w nipple	20	
5	W1108	Spoke (8/10G x 7 $\frac{7}{8}$ in. 90°) c/w nipple	20	
6	S79-2	Spoke nipple	40	
7	W1472	Hub	1	
8	W1499	Sprocket, 46T	1	
9	W1500	Bolt	8	
10	E1612	Serrated washer	8	
11	W1498	Brake drum	1	
12	W1690	Bolt ($\frac{1}{8}$ in. U.H.)	8	
13	W1691	Self locking nut	8	
14	W1281	Wheel spindle	1	
15	W1474	Grease retainer (brake side)	1	
16	W1654	Grease retainer	1	
17	W1022	Backing ring	1	
18	W653	Bearing	2	
19	W1021	RETAINING RING	1	
20	W1710	Locking screw ($\frac{3}{8}$ in. U.H.)	1	
21	W1278	Distance tube	1	
22	W1024	Distance piece	1	
23	W1112	Brake anchor plate	1	
24	W1282	Nut	1	
25	W1406	LEADING BRAKE SHOE C/W LINING	1	
26	W1407	TRAILING BRAKE SHOE C/W LINING	1	
27	NW243	Brake lining	2	
28	W129	Brass rivet	16	
29	W1415	Thrust pad	2	
30	W135	Shoe return spring	2	
31	W1083	Brake cam	1	
32	W1487	Brake cam lever	1	
33	W11	Pivot pin... ..	1	
34	S25-6	Plain washer	1	
35	S1-52	Nut	1	
36	W1488	Lever return spring	1	
37	W1635	Grease retainer	1	
38	W1476	Speedometer adaptor	1	
39	W1477	Distance piece	1	
40	D373	Speedometer gearbox	1	
41	W1280	Plain washer	1	
42	W1134	Chain adjuster	2	
43	W1015	Adjuster end plate	2	
44	W1058	Self-locking nut	2	
45	F1747	Spindle nut	3	
46	D106	Tyre security bolt... ..	2	
46	WM3	Tyre security bolt... ..	2	T100R, T100C

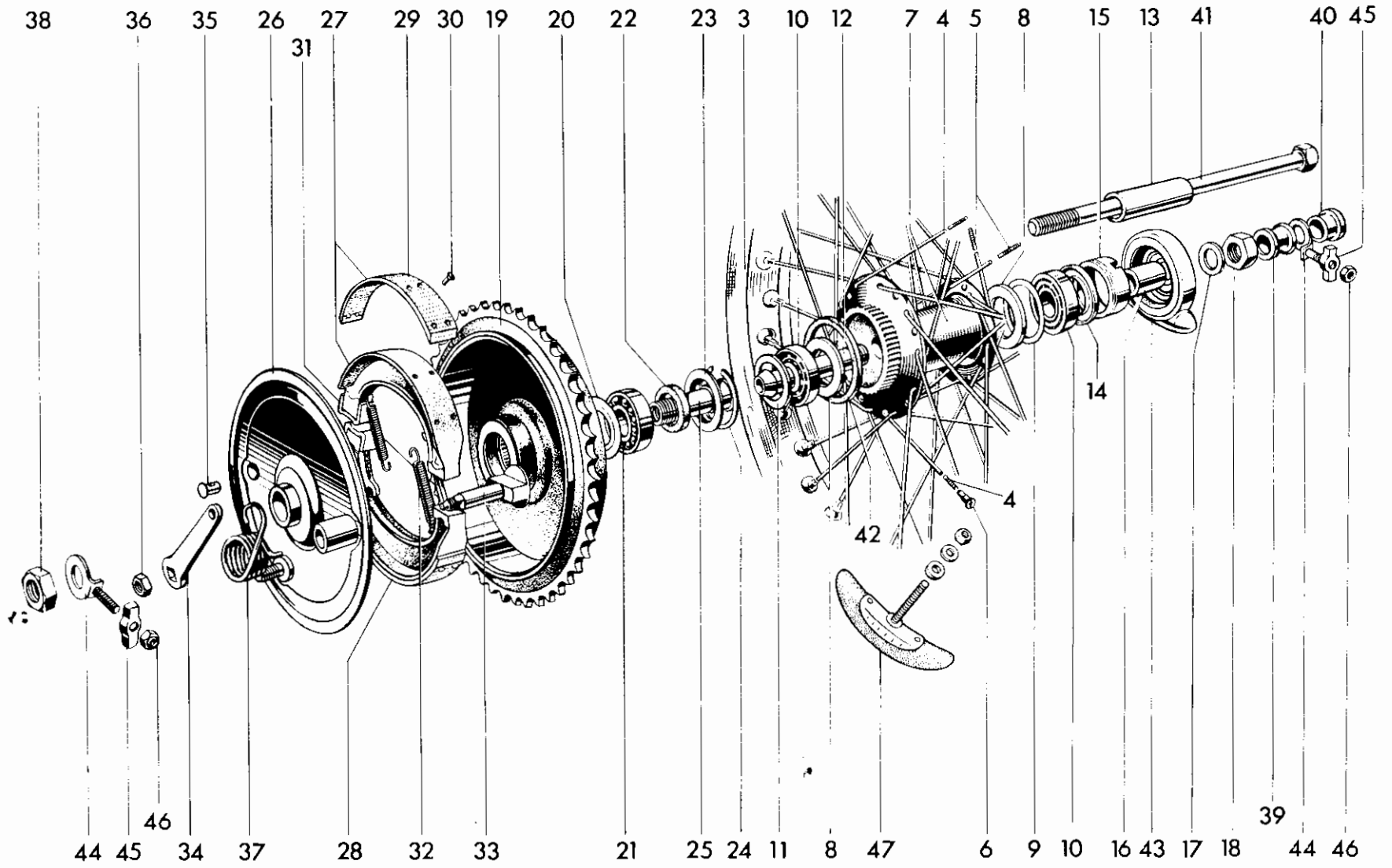

Fig. 21. QUICKLY DETACHABLE REAR WHEEL (NOT U.S.A.)

QUICKLY DETACHABLE REAR WHEEL (NOT U.S.A.)

1	W1746	Q.D. REAR WHEEL COMPLETE	1	
1	W1745	Q.D. REAR WHEEL COMPLETE	1	T100R, T100C
2	W1747	RIM, SPOKES AND HUB ASSEMBLY	1	
2	W1603	RIM, SPOKES AND HUB ASSEMBLY	1	T100R, T100C
3	W1471	Rear wheel rim WM2-18	1	
3	W1007	Rear wheel rim WM3-18	1	T100R, T100C
4	W1107	Spoke (8/10G x 7 $\frac{3}{8}$ in.90°) c/w nipple	20	
5	W1108	Spoke (8/10G x 7 $\frac{7}{8}$ in.90°) c/w nipple	20	
6	S79-2	Spoke nipple	40	
7	W1593	Hub	1	
8	W1595	Grease retainer	2	
9	W1509	Backing ring	2	
10	S35-7	Bearing	2	
11	W1596	Dust cap	1	
12	W1614	Bearing sleeve	1	
13	W1598	Distance piece (inner)	2	
14	W1635	Grease retainer	1	
15	W1599	Speedometer adaptor	1	
16	W1477	Distance piece (outer)	1	
17	W1280	Plain washer	1	
18	W1282	Nut	1	
19	W1040	Sprocket and brake drum 46T	1	
20	W1143	Grease retainer	1	
21	W1041	Bearing	1	
22	W1042	Felt washer	1	
23	W1043	Bearing and felt retainer	1	
24	W1044	Circlip	1	
25	W1045	Bearing sleeve	1	
26	W1121	Brake anchor plate	1	
27	W1406	LEADING BRAKE SHOE C/W LINING	1	
28	W1407	TRAILING BRAKE SHOE C/W LINING	1	
29	NW243	Brake lining	2	
30	W129	Brass rivet	16	
31	W1415	Thrust pad	2	
32	W135	Shoe return spring	2	
33	W1083	Brake cam	1	
34	W1487	Brake cam lever	1	
35	W11	Pivot pin	1	
36	S1-52	Nut	1	
37	W1488	Lever return spring	1	
38	W1052	Nut	1	
39	W1392	Inner distance piece	1	
40	W1170	Outer distance piece	1	
41	W1055	Spindle	1	
42	W1091	Rubber sealing ring	1	
43	D373	Speedometer gearbox	1	
44	W1135	Chain adjuster	2	
45	W1015	Adjuster end plate	2	
46	W1058	Self-locking nut	2	
47	D106	Tyre security bolt	2	
47	WM3	Tyre security bolt	2	T100R, T100C

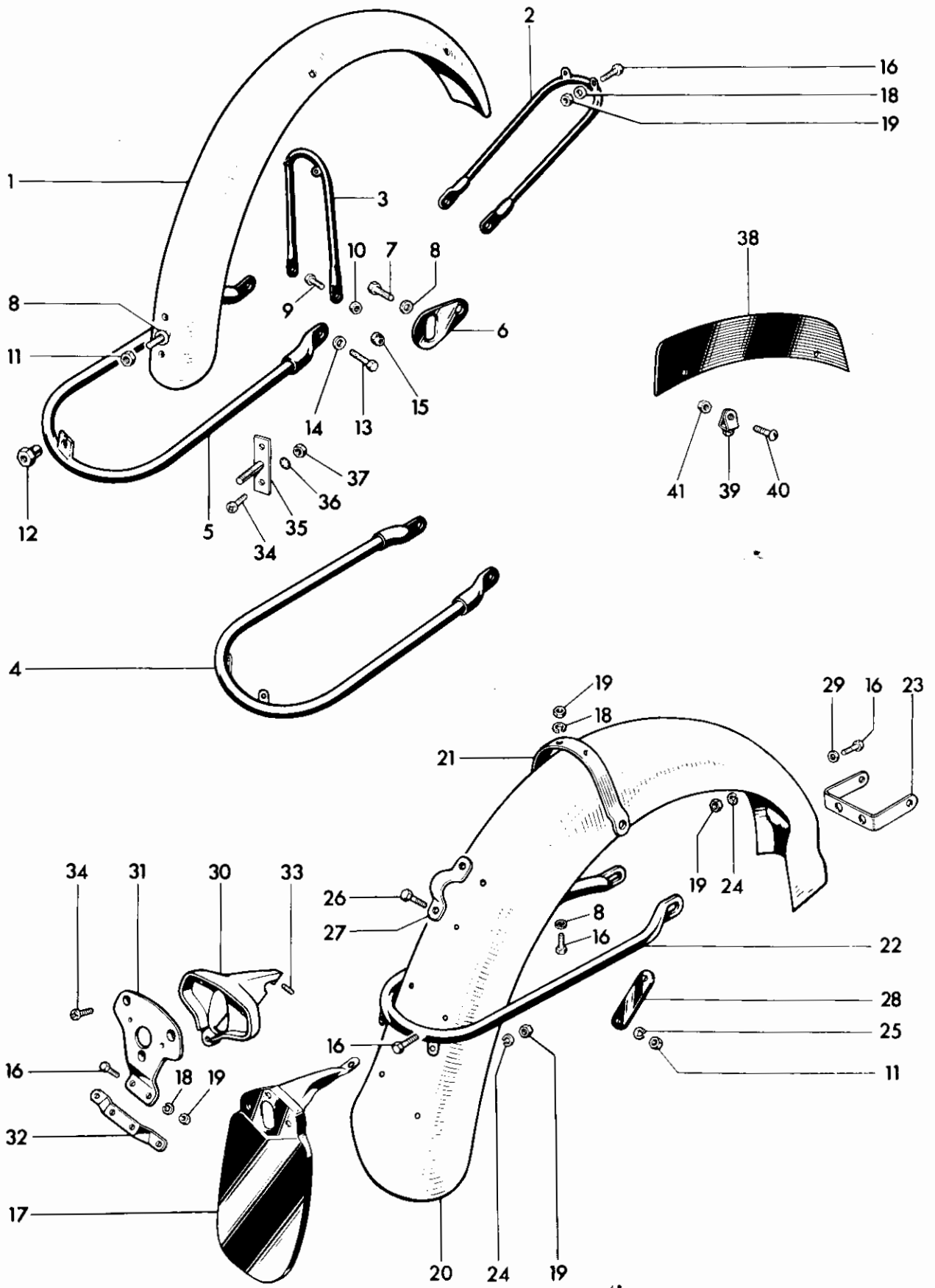

Fig. 22. MUDGUARDS (FENDERS U.S.A.)

Ref. No.	Part No.	DESCRIPTION	QUANTITY	REMARKS
MUDGUARDS (FENDERS U.S.A.)				
1	H1677	Front mudguard	1	
1	H1997	Front fender (stainless steel)	1	T100C
2	H1681	Front stay	1	
3	H1683	Centre bridge	1	
4	H1678	Bottom stay	1	
5	H1482	Bottom stay	1	
6	H1685	Bracket	2	
7	F929	Bolt ($\frac{1}{2}$ in. U.H.)	2	
8	F4299	Plain washer	3	
9	DS55	Bolt ($\frac{5}{16}$ in. U.H.)	4	
10	T224	Nut	2	
11	S1-51	Nut	3	
12	NS362	Spigot nut	1	
13	DS55	Bolt ($\frac{1}{16}$ in. U.H.)	2	
14	GS203	Plain washer	2	
15	W1691	Nut, self locking	2	
16	DS57	Bolt ($\frac{7}{16}$ in. U.H.)	13	
17	F5924	Rear number plate	1	
18	S25-1	Plain washer	5	
19	F879	Nut	13	
20	F5984	Rear mudguard	1	
20	F6965	Rear fender	1	T100R
20	F6967	Rear fender (stainless steel)	1	T100C
21	F6915	Fender bridge	1	
22	F5424	Lifting handle	1	
23	F6916	Bracket	1	
24	S26-2	Spring washer	5	
25	S26-3	Spring washer	2	
26	H590	Bolt ($\frac{9}{16}$ in. U.H.)	2	
27	F5994	Clip	1	
28	F6031	Backing plate	1	
29	F6310	Plain washer	3	
30	F6847	Tail lamp adaptor	1	} U.S.A. models
31	F6849	Tail lamp plate	1	
32	F6850	Number plate bracket	1	
33	E2980	Stud ($\frac{15}{16}$ in. O.A.)	1	
34	F4715	Screw ($\frac{13}{32}$ in. U.H.)	5	
35	H1998	Backing strip	1	
36	GS299	Serrated washer	2	
37	F3799	Nut	2	
38	F6470	Front number plate	1	
39	H741	Clip assembly	2	
40	H687	Screw ($\frac{3}{8}$ in. U.H.)	2	
41	H745	Nut	2	

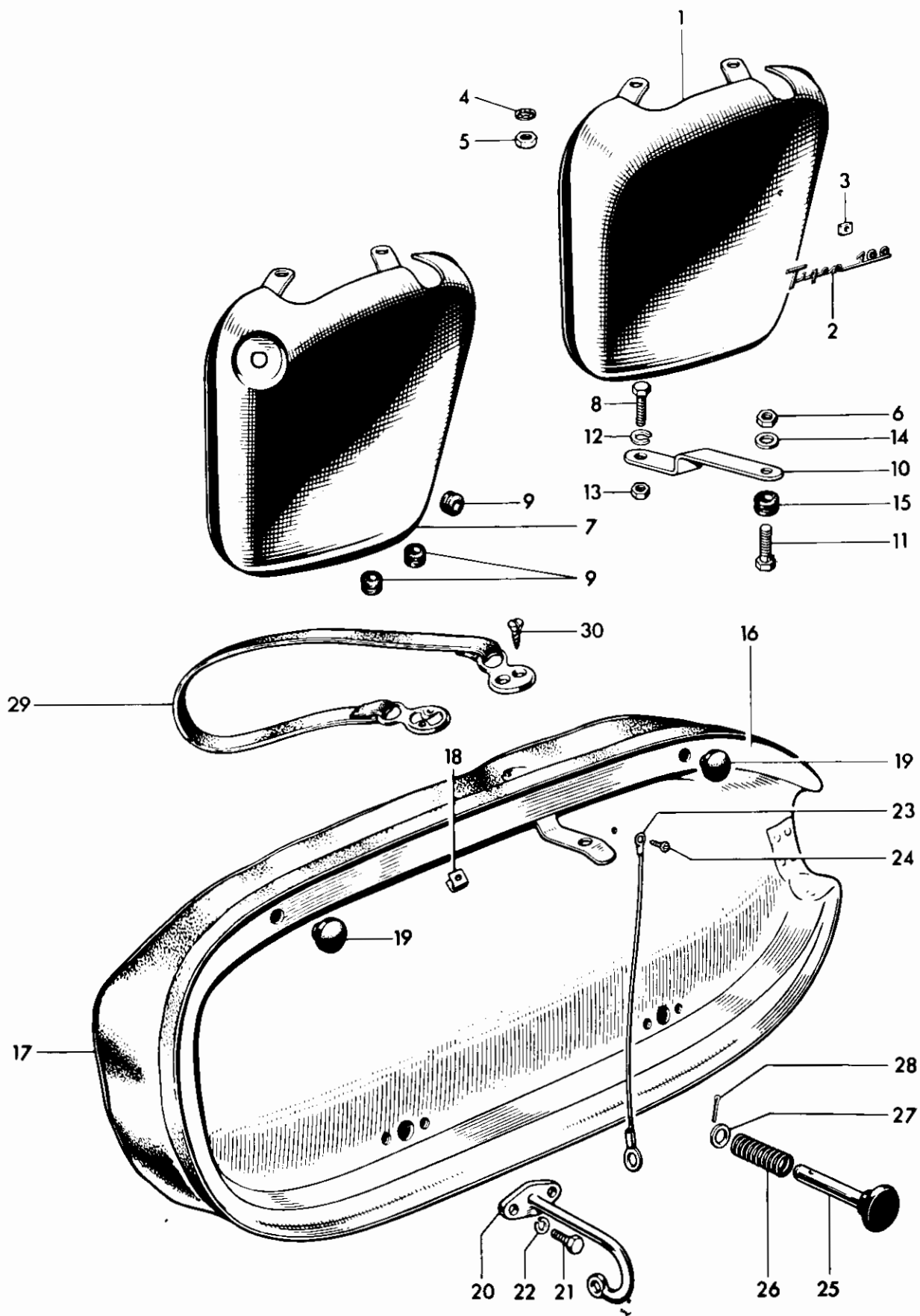

Fig. 23. PANELS AND TWINSEAT

PANELS AND TWINSEAT

1	F6964	Left panel	1	T100C
2	F6948	Motif "Tiger 90"	1	
2	F6949	Motif "Tiger 100"	1	
3	F4317	Spire nut	3	
4	E1612	Serrated washer	2	
5	13104/00/2	Nut	2	
6	15104/00/2	Self-locking nut	1	
7	F7361	Switch panel	1	T90, T100
8	F1369	Bolt ($\frac{5}{8}$ in. U.H.)	1	
9	F5466	Grommet	3	
10	F5976	Link	1	
11	11104/06/2	Bolt ($\frac{3}{4}$ in. U.H.)	1	
12	S26-2	Spring washer	1	
13	F879	Nut	1	
14	S25-43	Washer	1	
15	H961	Grommet	2	T100C
16	F7776	TWINSEAT (GREY TOP)	1	
16	F7482	TWINSEAT (BLACK TOP)	1	T100C and T100R
17	F7777	Twin seat cover c/w clips (GREY TOP)	1	
17	F7489	Twinseat cover c/w clips (BLACK TOP)	1	T100C and T100R
18	F4475	Clip	As	required
19	F4898	Rubber buffer	2	
20	F4222	Hinge	2	
21	DS57	Bolt ($\frac{7}{8}$ in. U.H.)	4	
22	S26-2	Spring washer	4	
23	D374	Check wire	1	
24	F4483	Self tapping screw	1	
25	F7560	Seat catch plunger c/w knob	1	
26	F4228	Spring	1	
27	E1719A	Plain washer	1	
28	$\frac{3}{32}$ in. x $\frac{1}{2}$ in.	Split pin	1	
29	F4361	Safety strap	1	T100C, T100R
30	F4365	Self tapping screw	4	
not illust.	{ F7775	Trim strip (Black)	1	T100C and T100R
	{ F7778	Trim strip (Grey)	1	

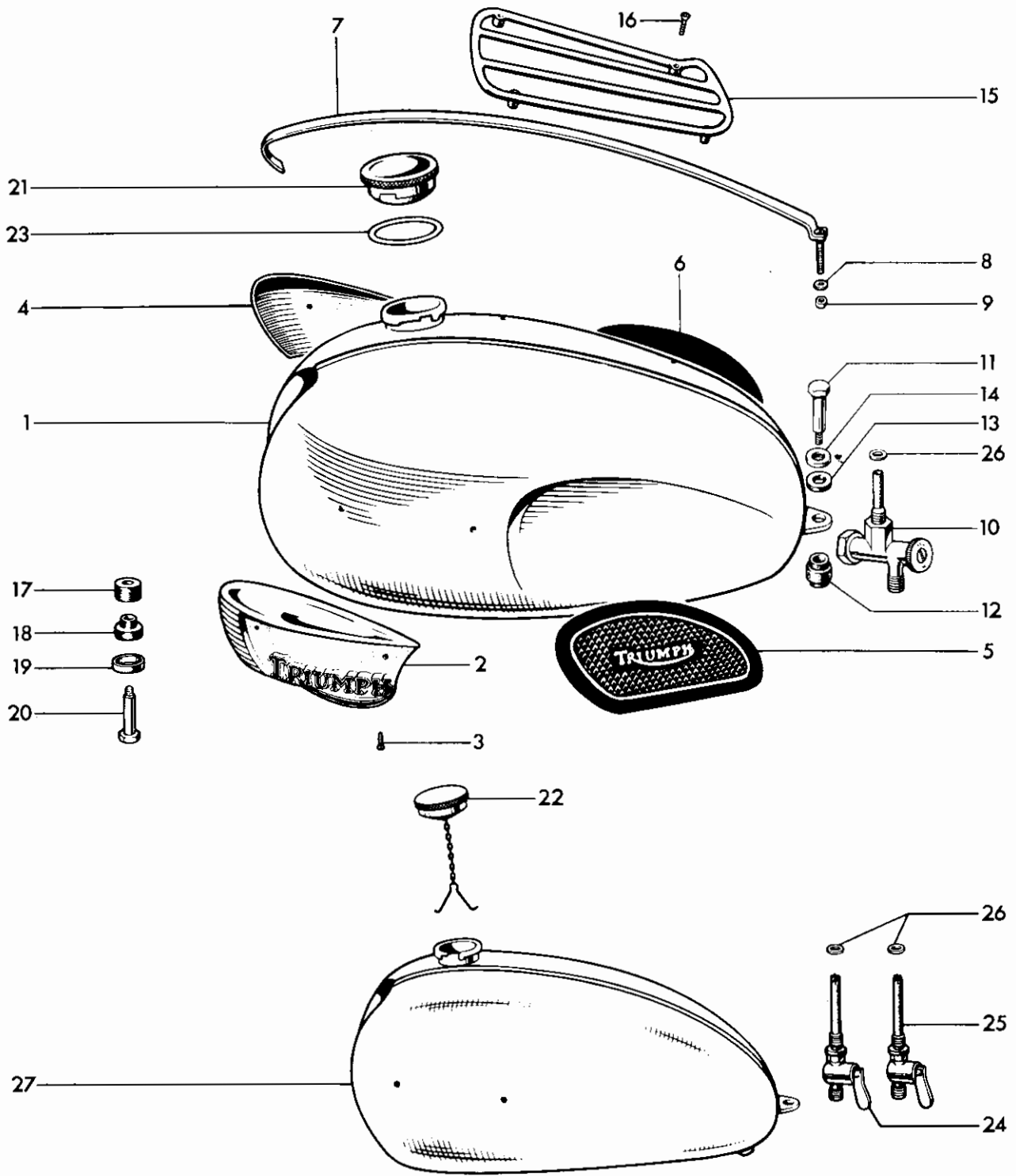

Fig. 24. PETROL TANK

PÉTROL (GAS) TANKS

1	F7393	Petrol tank (3 gallons)	1	T90, T100S, T100T
2	F6887	Styling unit (left)	1	
3	F4129	Styling unit screw (0.435 in. U.H.)	4	
4	F6888	Styling unit (right)	1	
5	F5401	Left knee grip	1	
6	F5402	Right knee grip	1	
7	F7395	Centre styling strip	1	
8	F4019	Serrated washer	1	
9	H919	Nut	1	
10	F1717	Petrol tap	1	T90, T100S, T100T
11	F7388	Rear bolt	1	
12	F5336	Double spigot rubber	1	
13	F967	Rubber washer	1	
14	F3814	Cup	1	
15	F3917	Parcel grid	1	T90, T100S, T100T
16	F2936	Screw	4	T90, T100S, T100T
17	F5228	Rubber washer	4	
18	F5229	Spigot rubber	4	3TA, 5TA, T90, T100
19	F3814	Cup	4	
20	F1808	Bolt	4	
21	F3220	FILLER CAP	1	
22	F3219	FILLER CAP c/w JACK CHAIN	1	
23	F4048	Joint washer	1	
24	F4971	Petrol tap (left)	1	} T100C, T100R
25	F4972	Petrol tap with reserve tube	1	
26	F1511	Fibre washer	2	
27	F7192	Petrol tank (2½ U.S. gallons)	1	

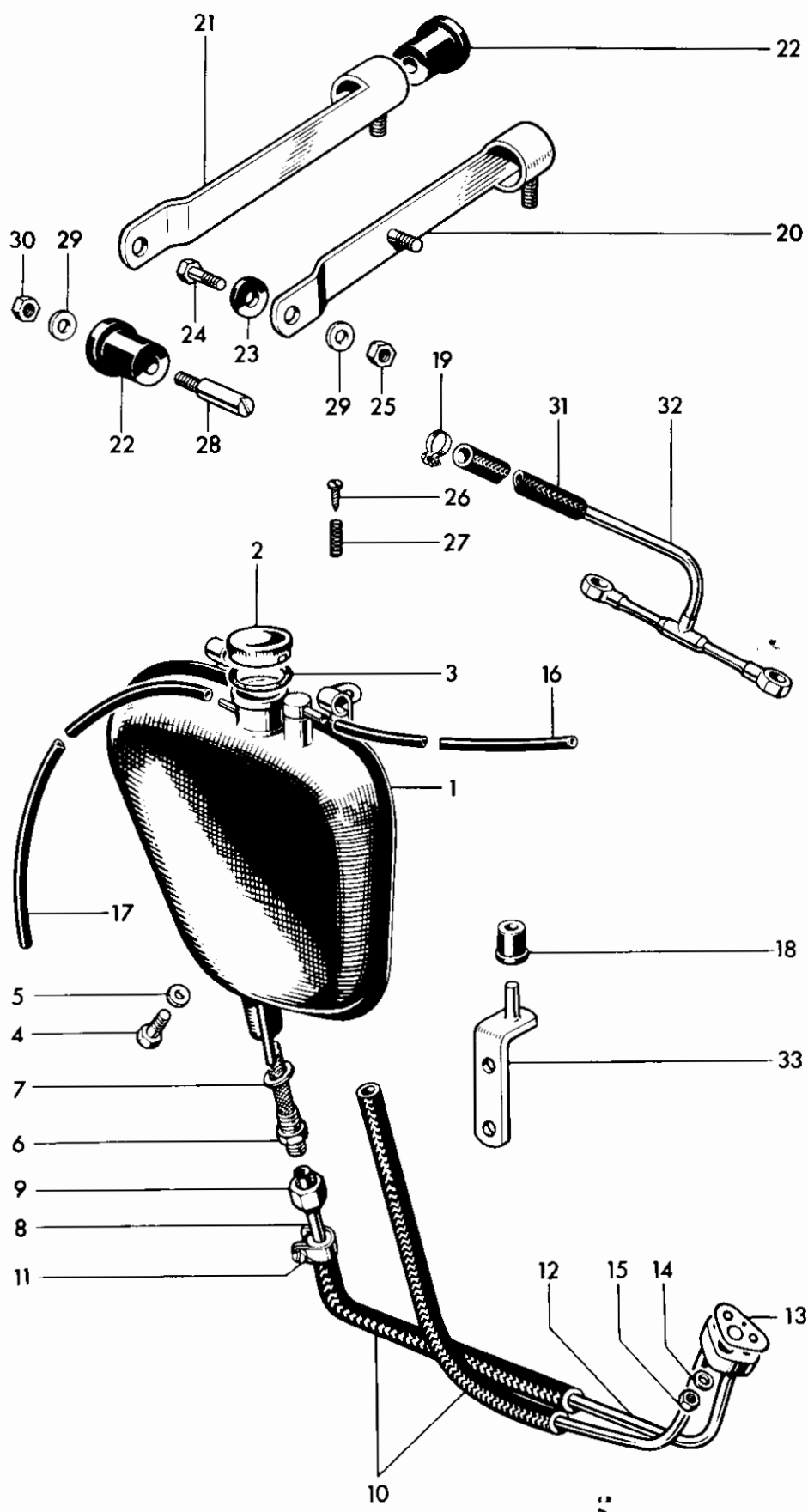

Fig. 25. OIL TANK

Ref. No.	Part No.	DESCRIPTION	QUANTITY	REMARKS
		OIL TANK		
1	F6877	Oil tank	1	
2	F3216A	FILLER CAP	1	
3	F4047	Joint washer	1	
4	F5343	Drain plug	1	
5	PT104B	Fibre washer	1	
6	F3179	Oil tank filter	1	
7	F1713	Fibre washer	1	
8	F6103	Upper feed pipe	1	
9	F3182	Union nut	1	
10	E4594	Flexible connector, long	2	
11	E5473	Clip	4	
12	E5434	Oil pipes and junction block	1	
13	E3763	Joint washer	1	
14	E3446	Plain washer	1	
15	E1310	Nut	1	
16	T1579	Vent pipe	1	
17	F7352	Flexible pipe (chain oiler)	1	
18	F6039	Grommet	1	
19	E6849	Clip (rocker pipe)... ..	1	
20	F7383	Front strap	1	
21	F7384	Rear strap	1	
22	F6673	Spigot rubber	4	
23	F6968	Rubber washer	2	
24	11104/06/2	Bolt ($\frac{3}{4}$ in. U.H.)	2	
25	15104/00/2	Self locking nut	2	
26	F6511	Metering screw	1	
27	F6874	Coil spring	1	
28	F6672	Screwed peg	2	
29	S25-13	Plain washer	4	
30	F879	Nut	2	
31	E6353	Rubber connector	1	
32	E6351	Rocker oil feed pipe	1	
33	F6898	Bracket	1	

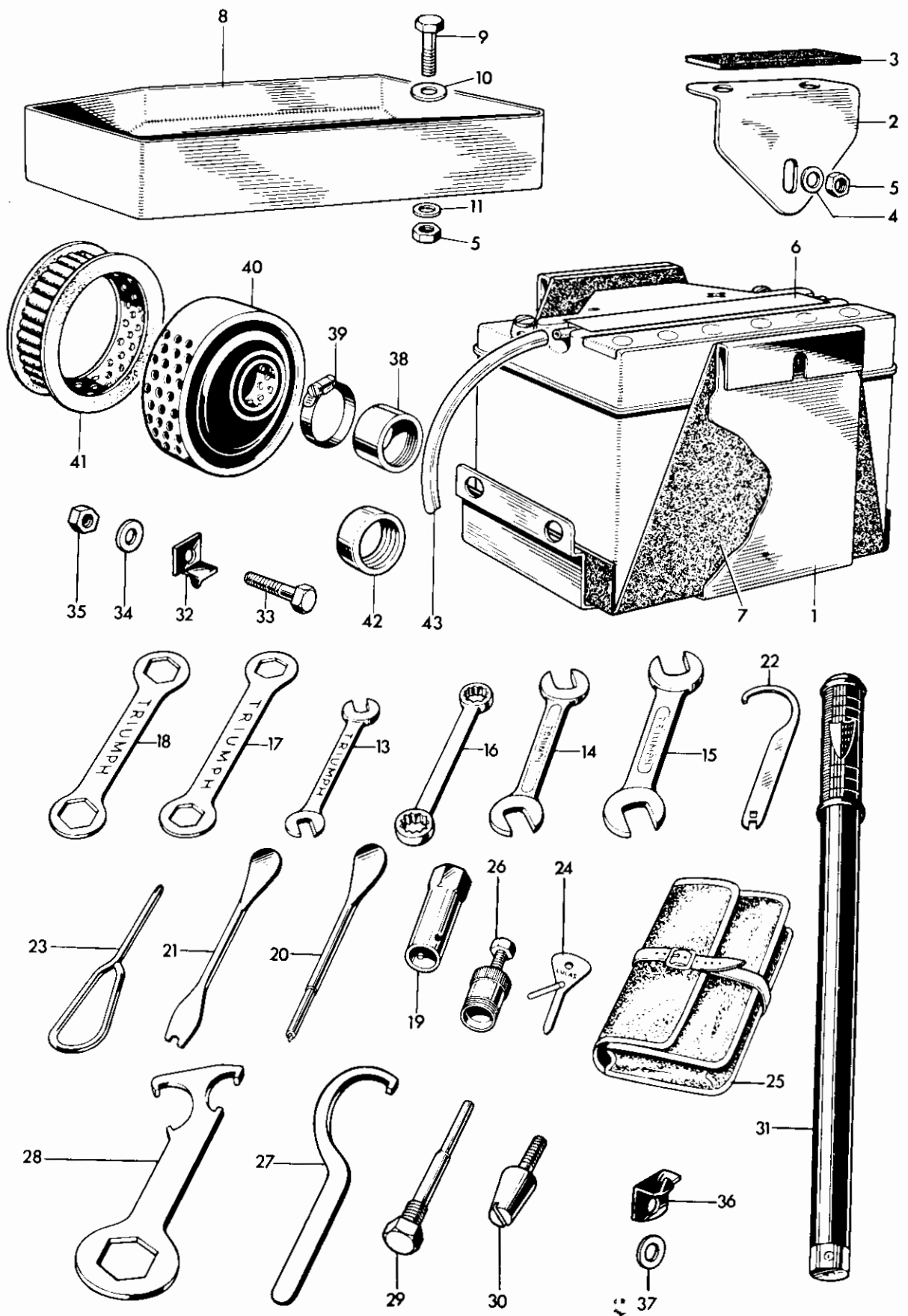

Fig. 26. BATTERY, TOOLKIT AND AIR FILTER

BATTERY, TOOLKIT AND AIR FILTER

1	*F6891	Battery carrier	1	
2	*F6897	Retainer	2	
3	F7345	Rubber	4	
4	S25-1	Plain washer	3	
5	13104/00/2	Nut	4	
6	*PUZ5A	Battery	1	
7	*F6969	Battery carrier lining	1	
8	F6901	Tool tray	1	
9	F1369	Bolt ($\frac{5}{8}$ in. U.H.)	2	
10	F7128	Plain washer	2	
11	S25-13	Plain washer	1	
12	D446	TOOL KIT	1	
13	D360	Open spanner, $\frac{1}{8}$ in. x $\frac{5}{16}$ in. whit.	1	
14	NA55	Open spanner, $\frac{1}{4}$ in. x $\frac{1}{16}$ in. whit.	1	
15	DA16	Open spanner, $\frac{3}{8}$ in. x $\frac{1}{16}$ in. whit.	1	
16	D370	Ring spanner, $\frac{1}{16}$ in. x $\frac{1}{4}$ in. whit.	1	
17	PA57	Ring spanner, $\frac{1}{2}$ in. x $\frac{1}{16}$ in. whit.	1	
18	D311	Ring spanner, $\frac{5}{8}$ in. x $\frac{1}{16}$ in. whit.		
19	D87	Box spanner, spark plug	1	
20	D363	Tyre lever and tommy bar	1	
21	D364	Tyre lever and clutch key	1	
22	D362	"C" spanner and tappet key	1	
23	D336	Phillips No. 3 screwdriver	1	
24	400935	Ignition screwdriver and feeler gauge	1	
25	D291	Tool roll	1	
26	DA50/1	Clutch hub extractor		as required
27	D527	Fork spanner (for sleeve nut)		as required
28	D220	Fork spanner (for cap nut)		as required
29	D484	Contact breaker extractor		as required
30	D486	Contact breaker assembly pilot		as required
31	D296	Tyre inflator	1	
32	F5432	Inflator top bracket	1	
33	F1369	Bolt ($\frac{5}{8}$ in. U.H.)	1	
34	S25-43	Plain washer	1	
35	S1-40	Nut	1	
36	F5433	Inflator bottom bracket	1	
37	S25-3	Plain washer	1	
38	F4812	Adaptor	4	
39	D177-9	Clip	1	or 2 T100R, T100T
40	F6430	AIR FILTER	1	T100S
41	F4811	Filter element (felt)	1	
40	F6433	AIR FILTER	1	T100C
41	F5694	Filter element (paper)	1	
40	F7772	AIR FILTER	2	T100T, T100R
41	F5764	Filter element (Coarse Felt)	2	
42	E4576	Adaptor, carb. to Filter	2	
43	F7431	Battery vent pipe	1	

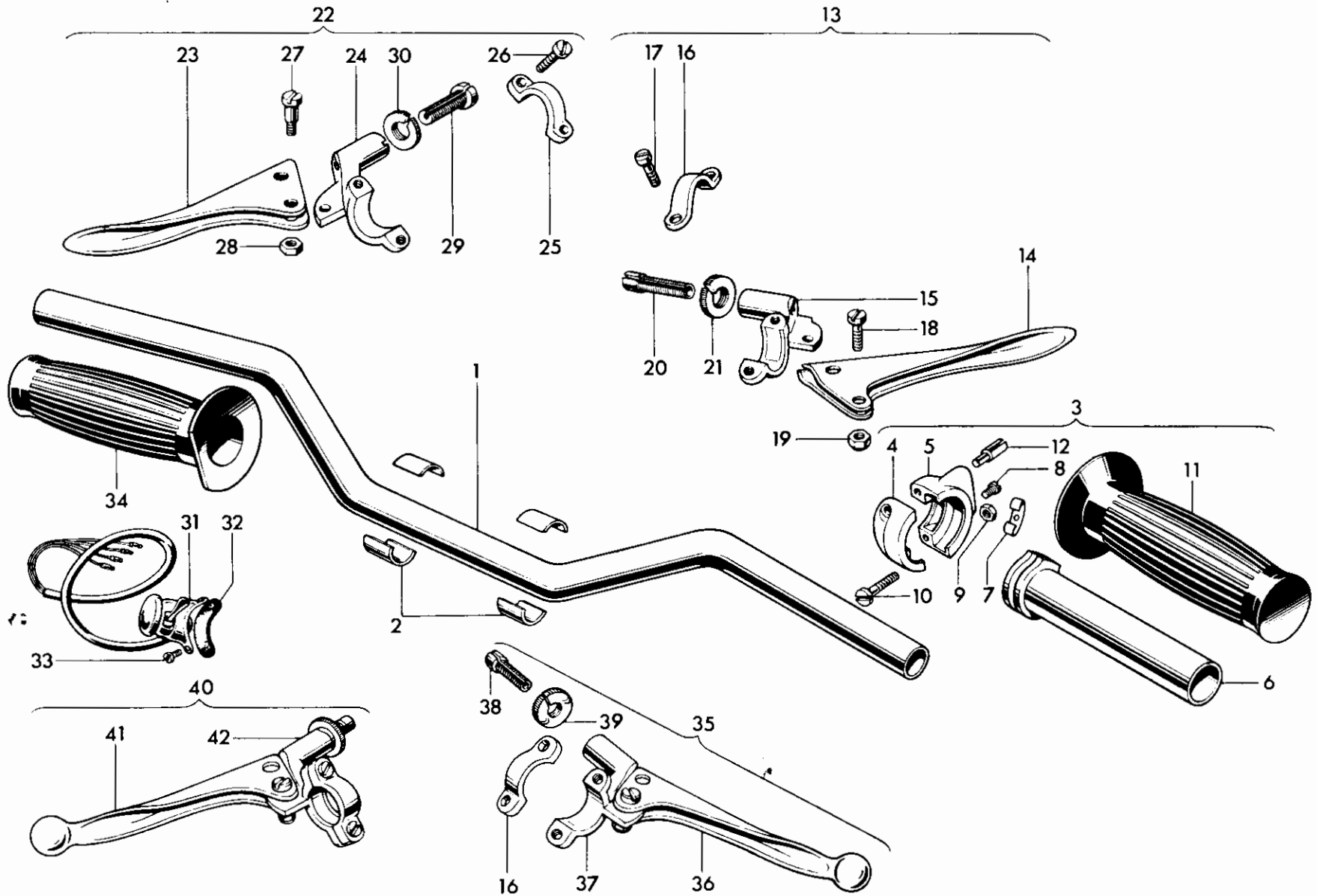

Fig. 27. HANDLEBARS AND CONTROL LEVERS

HANDLEBARS AND CONTROL LEVERS

1	H1871	Handlebar	1	T90, T100S, T100T
1	H1519	American handlebar	1	T100C
1	H1873	American handlebar	1	T100R
2	H1425	Packing piece	4	
3	16/364	TWISTGRIP	1	
4	16/328	Body top half	1	
5	16/329	Body bottom half	1	
6	16/091	Rotor	1	
7	16/008	Friction spring	1	
8	16/009	Friction spring screw	1	
9	16/010	Nut	1	
10	11/014	Screw	2	
11	H2125	Handlebar grip	1	
12	16/011	Cable stop	1	
13	18/999	FRONT BRAKE LEVER ASSEMBLY	1	
14	18/535	Brake lever	1	
15	18/1013	Brake lever bracket	1	
16	12/595	Clamp	1	
17	11/014	Screw	2	
18	18/087	Fulcrum screw	1	
19	18/053	Self-locking nut	1	
20	18/1005	Cable adjuster	1	
21	18/1006	Thumb nut	1	
22	18/1000	CLUTCH LEVER ASSEMBLY	1	
23	18/528	Clutch lever	1	
24	18/1009	Clutch lever bracket	1	
25	12/595	Clamp	1	
26	11/014	Screw	2	
27	18/087	Fulcrum screw	1	
28	18/053	Self-locking nut	1	
29	18/1005	Cable adjuster	1	
30	18/1006	Thumb nut	1	
31	31563	Horn push and dip switch	1	
32	380459	Backing rubber	1	
33	H1994	Screw (½ in. U.H.)	2	
34	H2142	Handlebar grip	1	
35	18/951	FRONT BRAKE LEVER ASSEMBLY (Ball-end)	1	} T100C, T100R
36	18/754	Brake lever (Ball-end)	1	
37	18/777	Brake lever bracket	1	
38	18/838	Cable adjuster	1	
39	18/839	Thumb nut	1	
40	18/952	CLUTCH LEVER ASSEMBLY (Ball-end)	1	
41	18/752	Clutch lever (Ball-end)	1	
42	18/773	Clutch lever bracket	1	

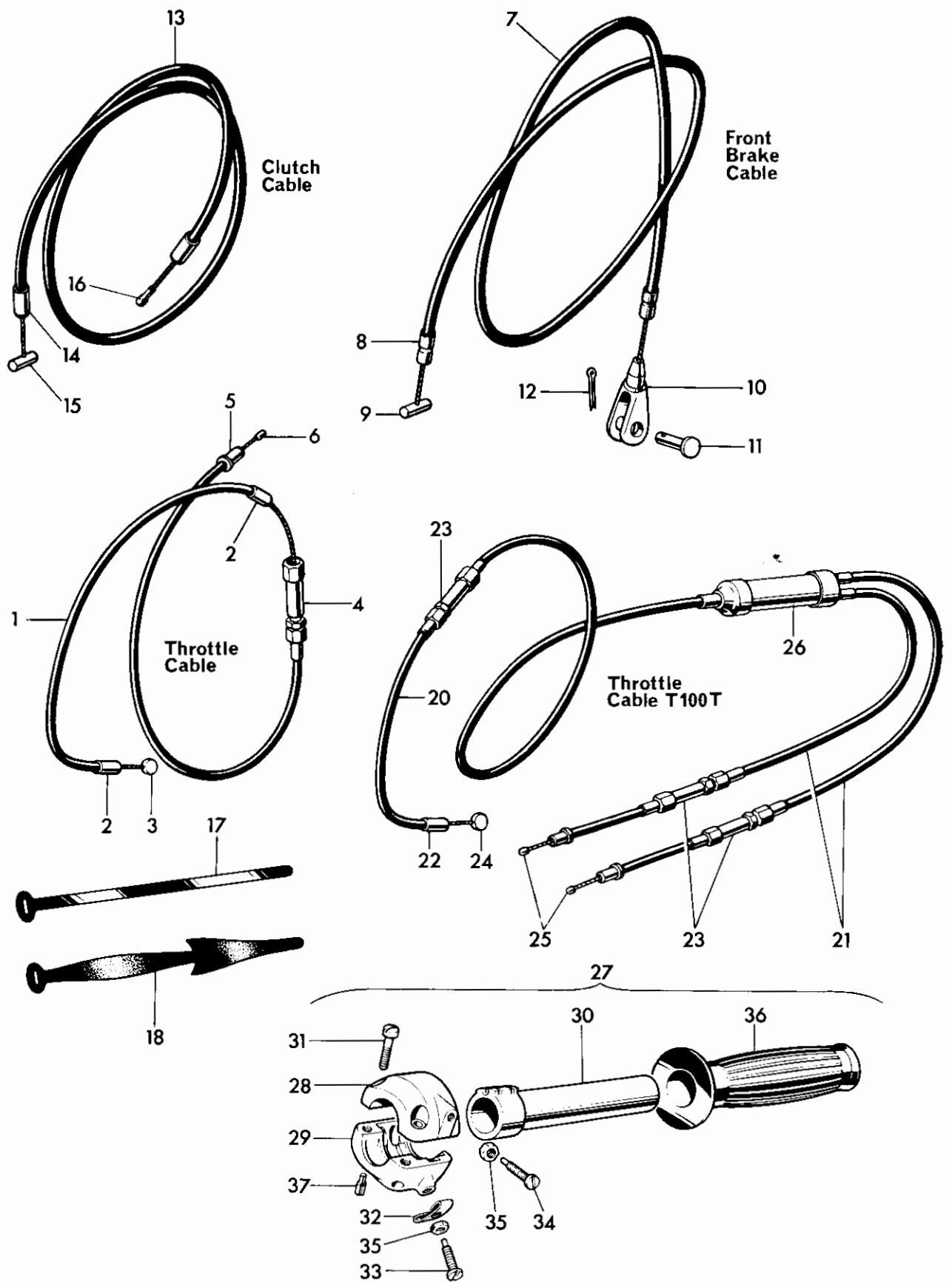

Fig. 28. CONTROL CABLES

Ref. No.	Part No.	DESCRIPTION	QUANTITY	REMARKS
CONTROL CABLES				
1	D528	THROTTLE CABLE	2	T100R
1	D495	THROTTLE CABLE	1	
2	D101	Ferrule	3	
3	D83	Nipple... ..	1	
4	D104	Adjuster	1	
5	6/132A	Ferrule	1	
6	NS191	Nipple... ..	1	
7	D560	FRONT BRAKE CABLE	1	
8	D103	Ferrule	2	
9	D506	Nipple... ..	1	
10	W593	Fork end	1	
11	WF32	Pivot pin	1	
12	$\frac{1}{8}$ in. x $\frac{3}{8}$ in.	Split pin	1	
13	D566	CLUTCH CABLE	1	
13	D565	AMERICAN CLUTCH CABLE	1	T100R, T100C
14	D103	Ferrule	2	
15	D506	Nipple... ..	1	
16	DS73	Nipple... ..	1	
17	XA69	Cable clip		As required
18	D343/7	Rubber cable clip	1	
19	D499	THROTTLE CABLE	1	} T100T
20	D500	Cable, twistgrip to junction box	1	
21	D423	Cable, junction box to carburetter	2	
22	D101	Ferrule	10	
23	D104	Adjuster assembly	3	
24	D83	Nipple... ..	1	
25	NS191	Nipple... ..	5	} T100R
26	244/104	Junction box	1	
27	313/13	TWIN ROTOR TWIST GRIP	1	
28	313/020	Body, top half	1	
29	313/021	Body, bottom half	1	
30	313/004	Rotor	1	
31	18/084	Bolt	2	
32	16/008	Friction spring	1	
33	210/007	Adjuster screw	1	
34	210/008	Rotor stop	1	
35	5/077	Nut	2	
36	H2125	Grip	1	
37	16/011	Cable stop	2	

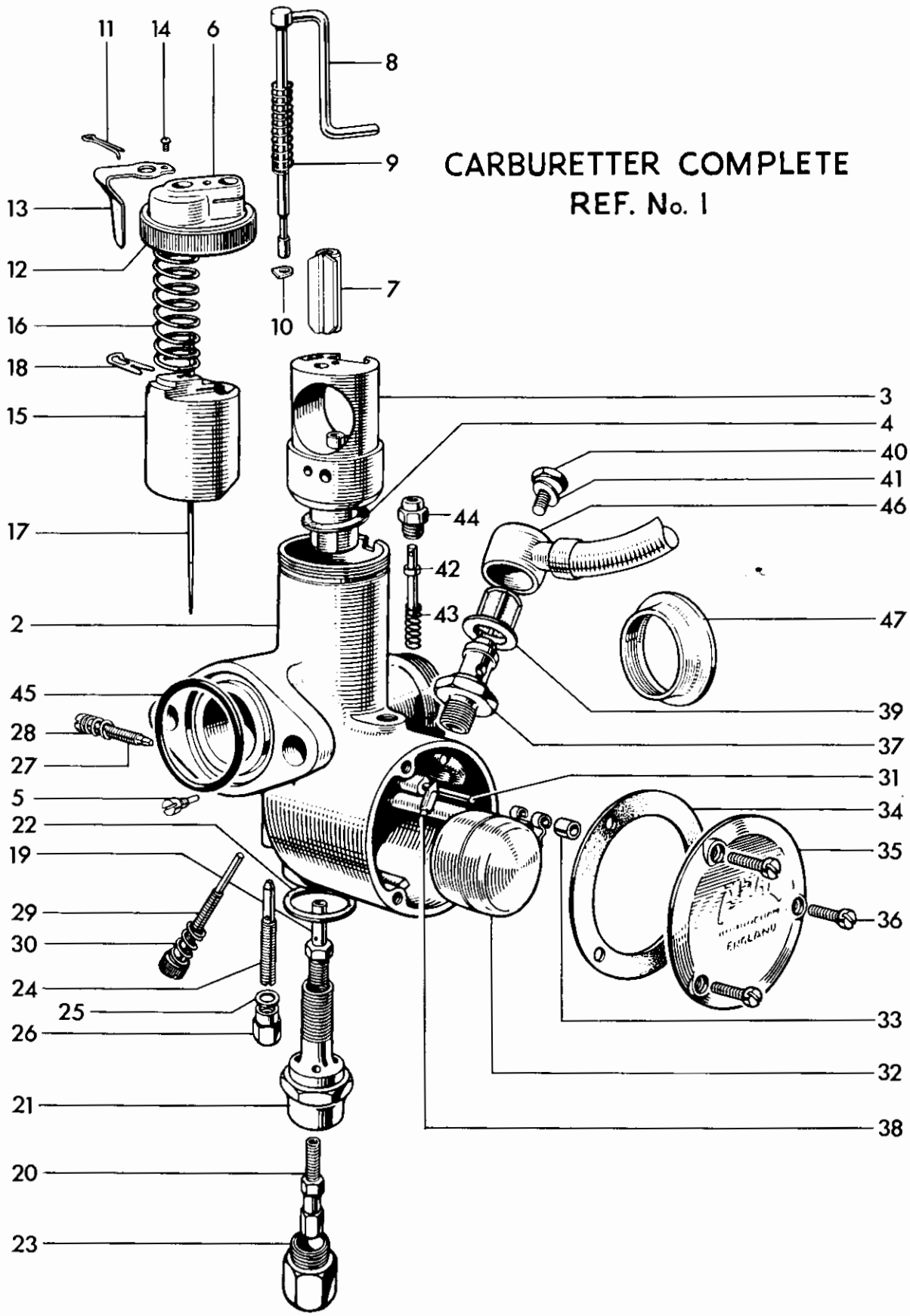

Fig. 29. CARBURETTER, T90, T100 AND T100C

Ref. No.	Part No.	DESCRIPTION	QUANTITY	REMARKS
CARBURETTER, T90, T100 AND T100C				
1	376/300	CARBURETTER, $\frac{1}{8}$ in. choke ...	1	T90
1	376/273	CARBURETTER, 1 in. choke ...	1	T100
2	376/001	Mixing chamber, $\frac{1}{8}$ in. choke ...	1	T90
2	376/002	Mixing chamber, 1 in. choke ...	1	T100
3	376/055	Jet block, $\frac{1}{8}$ in. choke ...	1	T90
3	376/056	Jet block, 1 in. choke ...	1	T100
4	376/067	Joint washer ...	1	
5	376/070	Peg screw ...	1	
6	376/158	Mixing chamber top ...	1	
7	376/197	Air valve ...	1	
8	376/402	Control rod and lever ...	1	
9	376/109	Return spring ...	1	
10	376/409	Friction washer ...	1	
11	30/064	Click spring ...	1	
12	376/065	Mixing chamber cap ...	1	
13	29/308	Spring ...	1	
14	4/241	Screw ...	1	
15	376/060	Throttle valve (3 cutaway) ...	1	T90
15	376/060	Throttle valve ($3\frac{1}{2}$ cutaway) ...	1	T100
16	376/061	Throttle return spring ...	1	
17	376/063	Needle (Type C) ...	1	
18	4/230	Needle clip ...	1	
19	376/072	Needle jet (-106) ...	1	
20	376/100	Main jet (180) ...	1	T90
20	376/100	Main jet (190) ...	1	See Pages 9 to 12
21	376/073	Jet holder ...	1	
22	376/074	Fibre washer ...	1	
23	376/075	Cover nut ...	1	
24	376/076	Pilot jet (20) ...	1	T90
24	376/076	Pilot jet (25) ...	1	T100
25	116/162	Fibre washer ...	1	
26	376/095	Cover nut ...	1	
27	332/017	Air adjusting screw ...	1	
28	4/148	Spring ...	1	
29	376/068	Throttle stop screw ...	1	
30	376/069	Spring ...	1	
31	376/085	Float spindle ...	1	
32	376/083	Float ...	1	
33	376/094	Bush ...	1	
34	376/078	Joint washer ...	1	
35	376/077	Cover ...	1	
36	376/079	Screw ...	3	
37	376/088	Needle seating ...	1	
38	376/089	Needle ...	1	
39	376/093	Filter ...	1	
40	376/091	Bolt ...	1	
41	376/092	Fibre washer ...	1	
42	376/086	Tickler ...	1	
43	376/087	Spring ...	1	
44	343/011	Tickler body ...	1	
45	244/1048	"O" ring seal... ...	1	
46	F6846	Petrol pipe ...	1	
47	376/066	Air intake tube ...	A	

CARBURETTER COMPLETE
REF. N°1

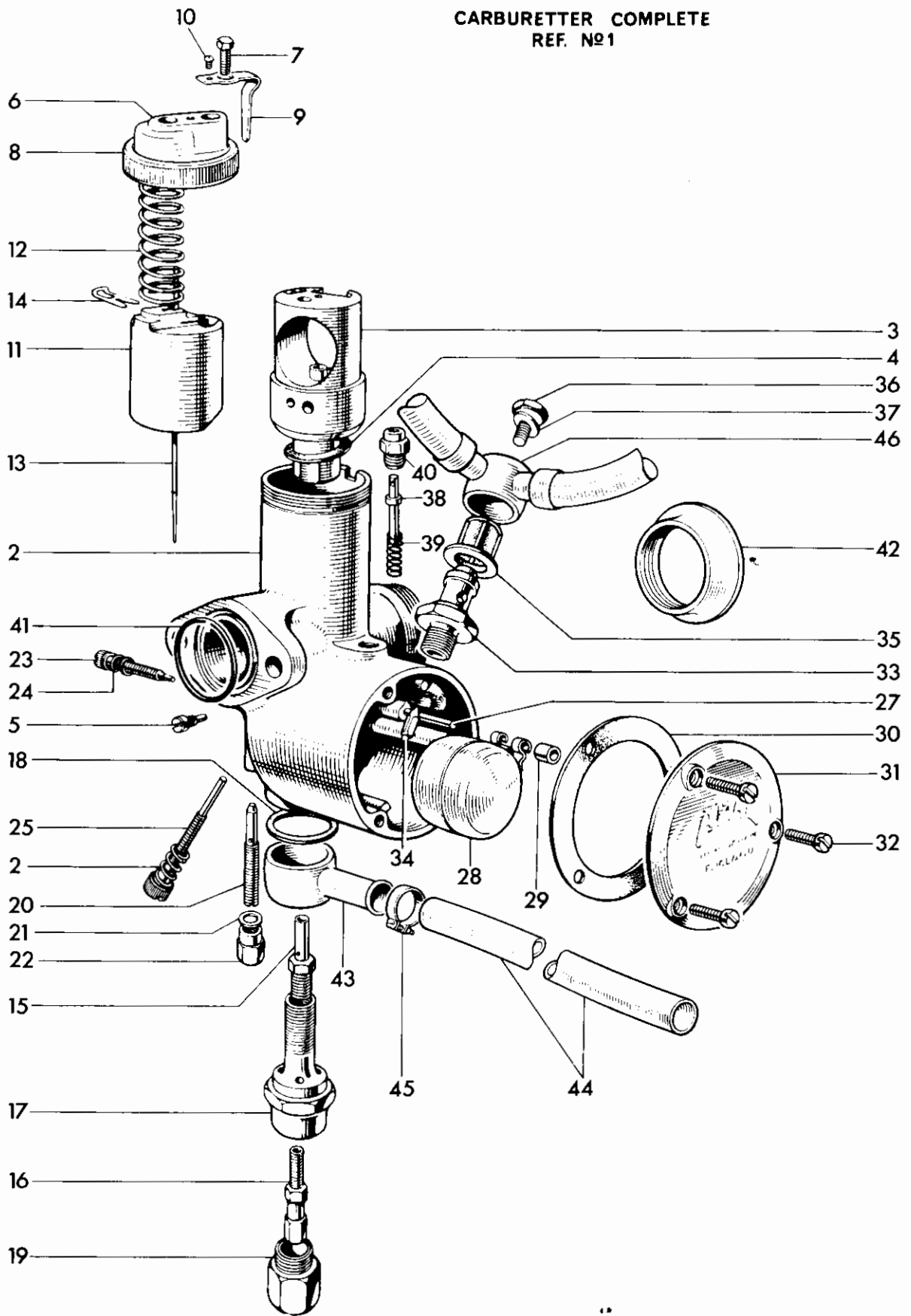

Fig. 30. CARBURETTER, T100T AND T100R

Ref. No.	Part No.	DESCRIPTION	QUANTITY	REMARKS
CARBURETTER, T100T AND T100R				
1	376/324	Carburetter 1 $\frac{1}{8}$ in. choke	1	Left
1	376/325	Carburetter 1 $\frac{1}{8}$ in. choke	1	Right
2	376/003	Mixing chamber 1 $\frac{1}{8}$ in. choke	1	Left
2	376/164	Mixing chamber 1 $\frac{1}{8}$ in. choke	1	Right
3	376/057	Jet block 1 $\frac{1}{8}$ in. choke	2	
4	376/067	Joint washer	2	
5	376/070	Peg screw	2	
6	376/107	Mixing chamber top	2	
7	4/137A	Plug screw	2	
8	376/065	Mixing chamber cap	2	
9	29/308	Spring	2	
10	4/241	Screw	2	
11	376/060	Throttle valve (3 $\frac{1}{2}$ cutaway)	2	
12	376/132	Throttle return spring	2	
13	376/063	Needle (type C)	2	
14	4/230	Needle clip	2	
15	376/072	Needle Jet (.106)	2	
16	376/100	Main jet (200)	2	
17	376/140	Jet holder	2	
18	376/074	Fibre washer	4	
19	376/075	Cover Nut	2	
20	376/076	Pilot jet (2S)	2	
21	116/162	Fibre washer	2	
22	376/095	Cover nut	2	
23	332/017	Air adjusting screw	2	
24	4/148	Spring	2	
25	376/068	Throttle stop screw	2	
26	376/069	Spring	2	
27	376/085	Float spindle	1	
28	376/083	Float	1	
29	376/094	Bush	2	
30	376/078	Joint washer	2	
31	376/077	Cover	2	
32	376/079	Screw	6	
33	376/088	Needle seating	1	
34	376/089	Needle	1	
35	376/093	Filter	1	
36	376/091	Bolt	1	
37	376/092	Fibre washer	1	
38	376/086	Tickler	1	
39	376/087	Spring	1	
40	343/011	Tickler body	1	
41	244/1048	"O" ring seal...	1	
42	376/066	Air intake tube		As required
43	376/141	Banjo connection	2	
44	F7564	Petrol pipe, carb. to carb.	1	
45	E6848	Clip	2	
46	F7747	Petrol pipe assy.	1	T100T
46	F7708	Petrol pipe assy.	1	T100R

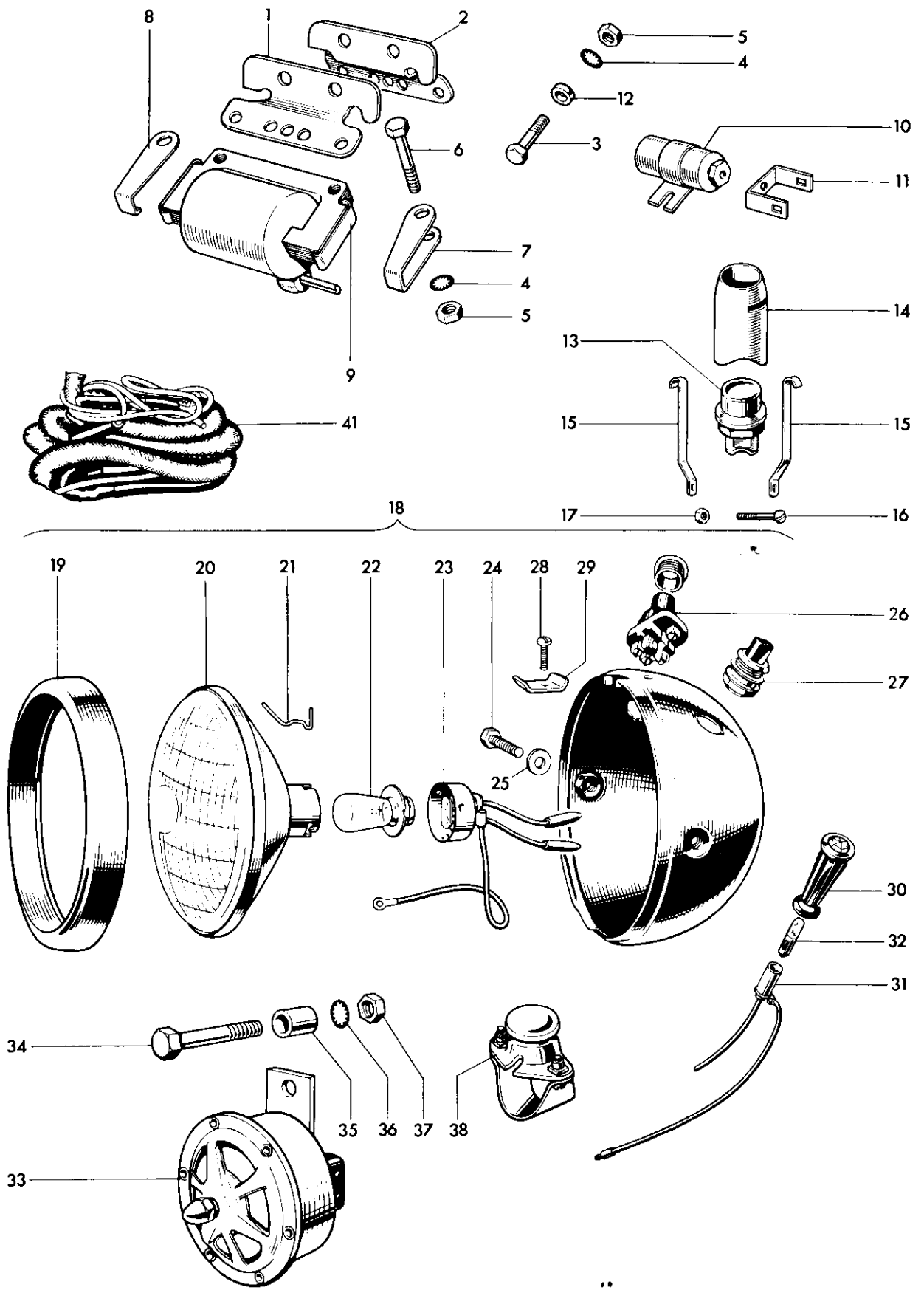

Fig. 31. A.C. MAGNETO IGNITION COILS, WIRING HARNESS AND DIRECT LIGHTING

A.C. MAGNETO IGNITION COILS AND DIRECT LIGHTING

1	F7182	Left coil bracket	1	} T100C, T100R
2	F7331	Right coil bracket	1	
3	F2335	Bolt ($\frac{1}{8}$ in. U.H.)	2	
4	S26-3	Spring washer	2	
5	S1-51	Nut	2	
6	F1369	Bolt ($\frac{5}{8}$ in. U.H.)	4	} T100R
6	W932	Bolt (1 in. U.H.)	4	
7	F6125	Retainer	2	} T100C
8	F6136	Retainer	2	
9	45149	Ignition coil, type 3ET	2	
10	5441582	Condenser	2	} T100R
11	54190108	Lucar terminal	2	
12	F2184	Distance piece	1	} T100C, T100R
13	31071	Cut-out button, type SS5	1	
14	H2033	Cup	1	
15	H2034	Clip	2	
16	H687	Bolt ($\frac{3}{8}$ in. U.H.)	1	
17	H745	Nut	1	
18	59699	HEADLAMP ASSEMBLY, MCH 66	1	} T100C
19	534343	Rim	1	
20	54520452	Light unit	1	
21	504665	Fixing wire	6	
22	166	Bulb (24/24W. Pre-focus, Vertical dip)	1	
23	554602	Adaptor	2	
24	112201	Bolt	2	
25	137499	Washer	2	
26	31356	Lighting switch	1	
27	31620	Dip switch	1	
28	144921	Screw	1	
29	534296	Plate	1	
30	38189	Hi-beam warning light	1	
31	54945043	Warning bulbholder	1	
32	282	Bulb...	1	
33	D552	Horn, clear hooters AC585SG	1	
34	11104/06/2	Bolt	1	
35	F4366	Distance Piece	1	
36	E1612	Serrated washer	1	
37	15104/00/2	Nut	1	
38	D553	Horn, push, clear hooters No. 10	1	
39	53972	STOP AND TAIL LAMP, type 679	1	
40	384	Bulb (6/18W. offset pin)	1	
41	54937097	Wiring harness	1	

39 and 40 not illustrated

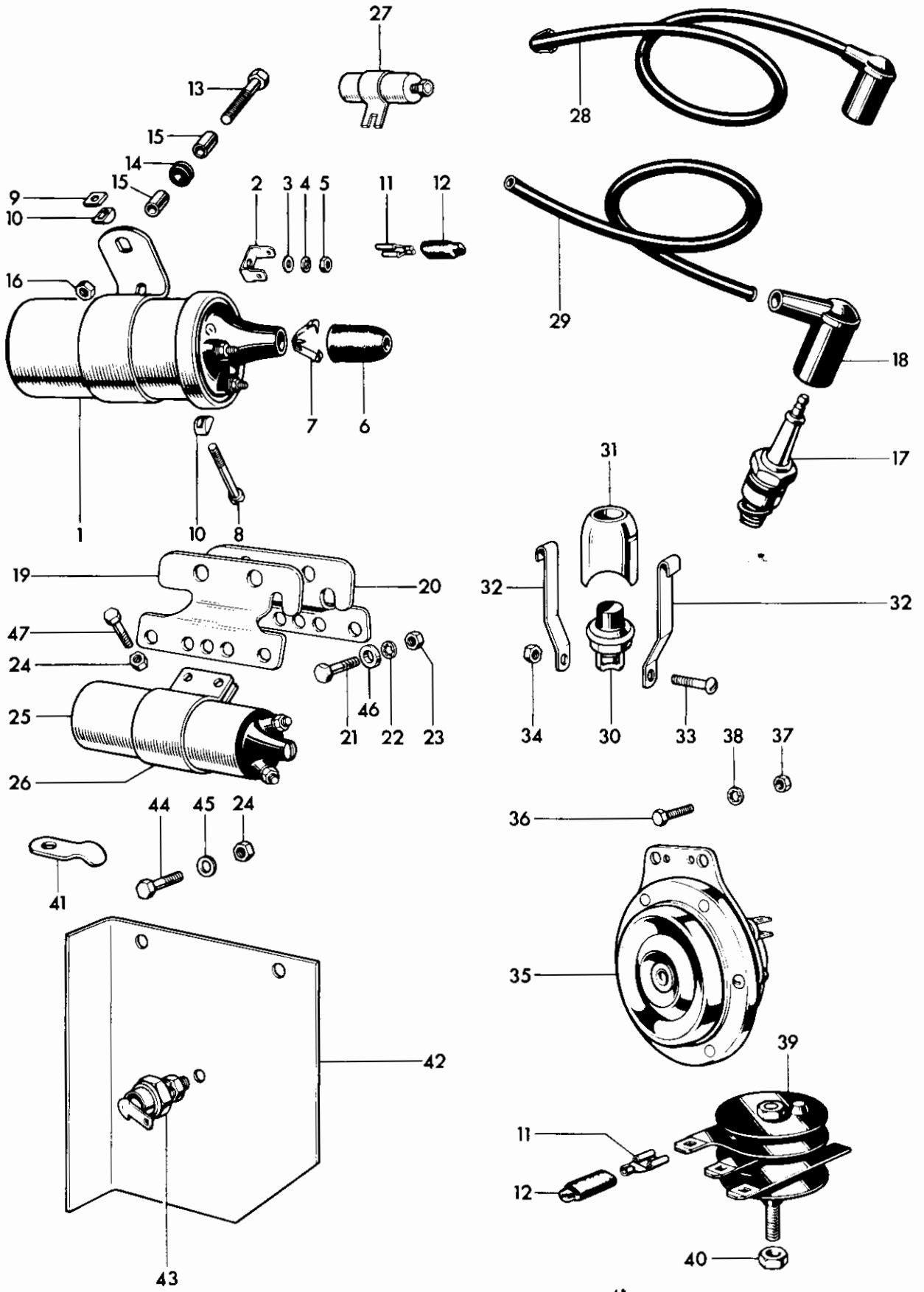

Fig. 32. D.C. IGNITION COILS, HORN, RECTIFIER AND ZENER DIODE

Ref. No.	Part No.	DESCRIPTION	QUANTITY	REMARKS
D.C. IGNITION COILS, HORN, RECTIFIER AND ZENER DIODE				
1	45110	IGNITION COIL, Type MA12	2	} T90, T100S and T100T
2	54190108	Lucar terminal	4	
3	131023	Plain washer (E2351)	4	
4	188330	Serrated washer (GS299)	4	
5	166043	Nut (F3799)	4	
6	421554	Rubber grommet	2	
7	421863	Cable clip	2	
8	100104	Screw	2	
9	169160	Square nut	2	
10	422369	"D" washer	4	
11	5492078	Lucar connector	As required	
12	54190042	Insulating cover	As required	
13	F3809	Bolt ($1\frac{3}{4}$ in. U.H.)	2	
14	F5466	Rubber grommet	2	
15	F5467	Distance piece	4	
16	E3290	Self locking nut	2	
17	—	Sparking plug (Champion N4)	2	
18	D262	Plug cover	2	
19	F7182	Left coil bracket	1	} T100R
20	F7331	Right coil bracket	1	
21	F2335	Bolt ($\frac{1}{8}$ in. U.H.)	2	
22	S26-3	Spring washer	2	
23	S1-51	Nut	2	
24	F879	Nut	6	
25	E6388	Ignition coil, Siba 32,000	2	
26	E6389	Clip, Siba 32,000/1	2	
27	54441582	Condenser	2	
28	54937976	H.T. lead complete (resistive)	2	
29	842183	H.T. lead (7 mm. cable)	2	T100R
30	35601	Cut-out button, type SS5	1	"Kill button"
31	H2033	Cup	1	
32	H2034	Clip	2	
33	H687	Bolt ($\frac{3}{8}$ in. U.H.)	1	
34	H745	Nut	1	
35	70197	Horn, type 6H	1	
36	F4771	Screw ($\frac{3}{8}$ in. U.H.)	2	
37	F3799	Nut	3	
38	GS299	Serrated washer	3	
39	49072	Rectifier, type 2DS 506	1	
40	F3338	Nut (156 596)	1	
41	F7399	Cable clip at heat sink	1	
42	F7237	Heat sink	1	
43	49345	Zener diode	1	
44	DS57	Bolt ($\frac{7}{16}$ in. U.H.)	2	
45	S25-1	Washer	2	
46	F2184	Distance piece	1	
47	F1369	Bolt($\frac{5}{8}$ in. U.H.)	4	

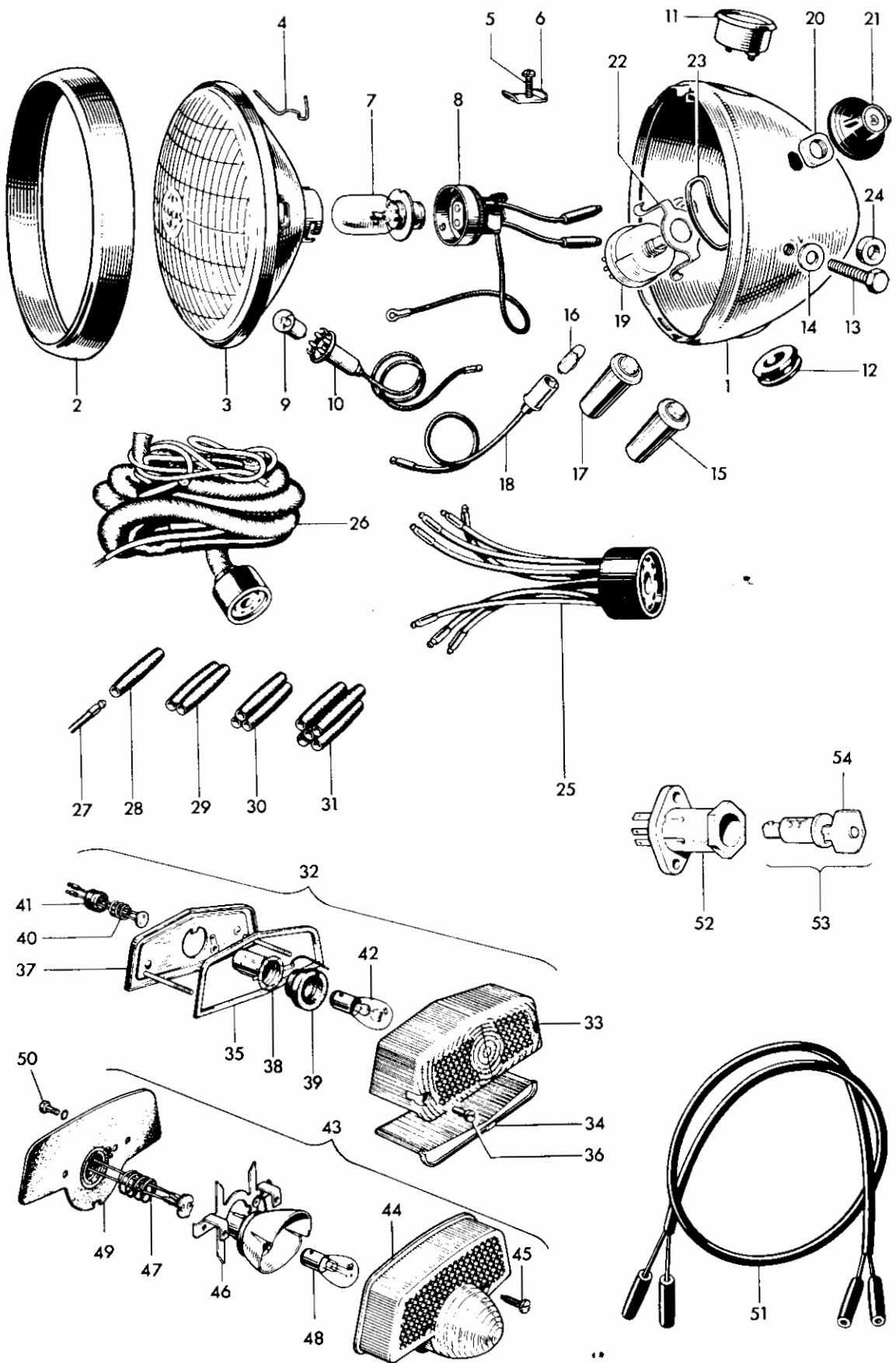

Fig. 33. HEADLAMP, WIRING HARNESS, SWITCHES AND TAIL LAMP

HEADLAMP, WIRING³ HARNESS, SWITCHES AND TAIL LAMP

1	59734	HEADLAMP COMPLETE	1	
2	553248	Rim	1	
3	516798	Light unit	1	
4	504665	Fixing wire	6	
5	144921	Screw	1	
6	534296	Plate	1	
7	446	Bulb (50/40 W. Vert dip. Pre-focus)	1	
8	554602	Main bulbholder	1	
9	989	Bulb (3 W. M.C.C.)	1	
10	554710	Pilot bulbholder	1	
11	36296	Ammeter, type 2AR...	1	
12	862217	Grommet	1	
13	112201	Bolt	2	
14	137498	Plain washer	2	
15	38189	Warning light body (Red)	1	
16	281	Bulb (2W. BA7S)	1	
17	38191	Warning light body (Green)	1	
18	54945043	Warning bulbholder	2	
19	34289	Lighting switch, type 88SA	1	
20	180316	Nut	1	
21	54330934	Knob c/w screw	1	
22	F5983	Bracket	1	
23	F5988	Rubber band	1	
24	H1932	Distance piece	2	
25	54930007	Replacement harness socket (Lighting)	1	
26	54950449	Wiring harness	1	
27	900269	Snap connector terminal	As required	
28	900288	Single snap connector	As required	
29	850641	Double snap connector	As required	
30	850844	Triple snap connector	As required	
31	850832	Quintuple snap connector	As required	
32	53454	STOP AND TAIL LAMP, Type 564	1	} T90, T100S, T100T
33	573839	Lens	1	
34	575200	Window	1	
35	575208	Lens seating gasket	1	
36	575219	Sleeve nut	2	
37	576002	Base assembly	1	
38	575209	Bulbholder	1	
39	575207	Grommet	1	
40	573828	Contact assembly	1	
41	573825	Grommet	1	
42	380	Bulb (6/21W. Offset pin)	1	} T100R
43	53973	STOP AND TAIL LAMP, Type L679	1	
44	54572932	Lens	1	
45	572289	Screw	2	
46	54574348	Bulb holder with reflector	1	
47	573828	Contact assembly	1	
48	380	Bulb (6/21 W. Offset pin)	1	
49	54571677	Gasket	1	
50	127684	Screw	2	
51	838604	Stop and tail lamp lead	1	
52	31899	Ignition switch, type S45	1	
53	F6981	IGNITION LOCK c/w KEYS	1	
54	—	Ignition key (state serial number)	As required	

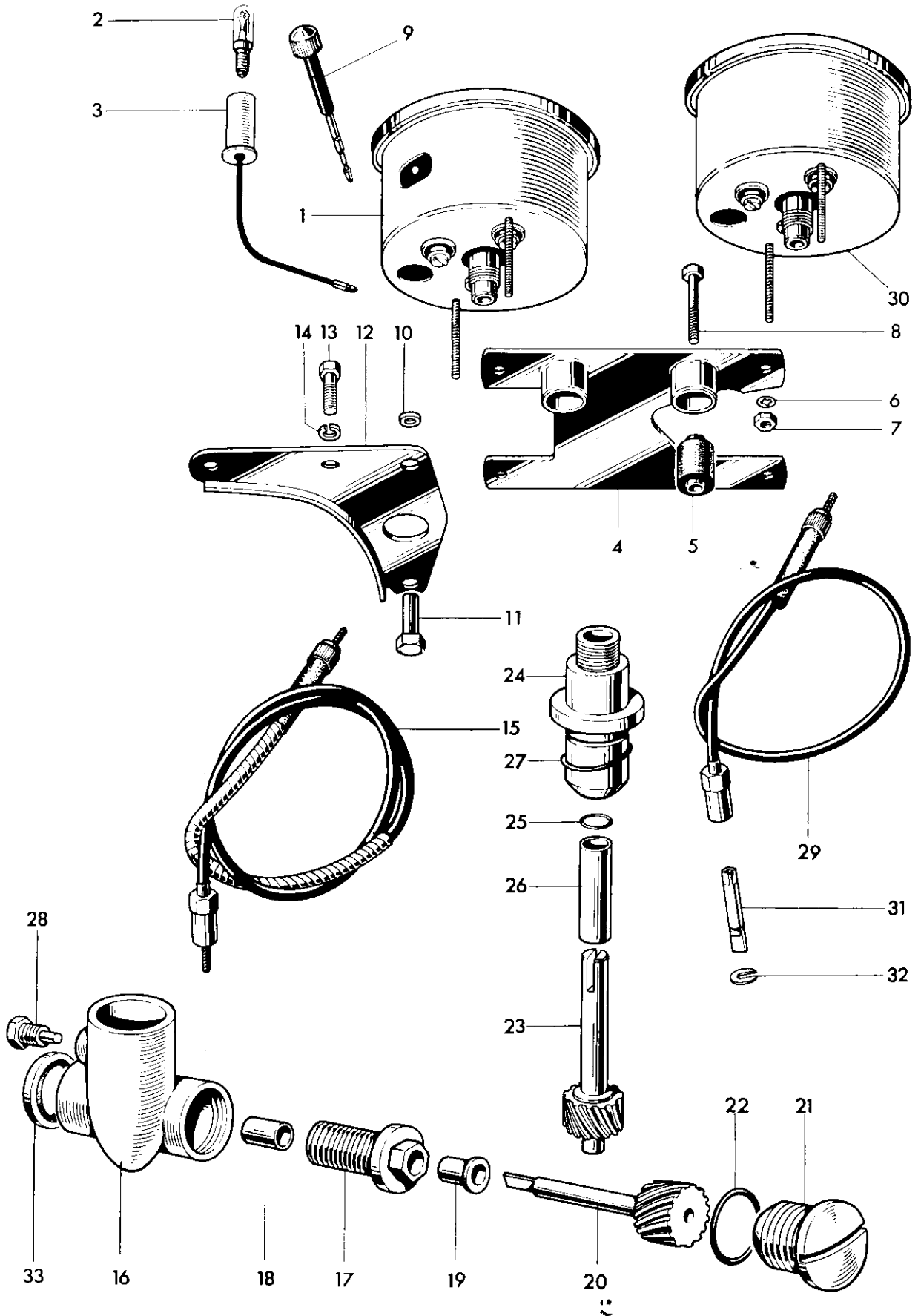

Fig. 34. SPEEDOMETER AND TACHOMETER

SPEEDOMETER AND TACHOMETER

1	SSM5001/00	Speedometer head MPH ...	1	T90, T100
1	SSM5001/01	Speedometer head KPH ...	1	Alternative
2	554734	Bulb holder ...	1	
3	987	Bulb, 3.W. M.E.S. ...	1	
4	H1946	MOUNTING BRACKET ...	1	
5	H1929	Metalastik bush ...	2	
6	30-282-014-11	Washer ...	2	T100R
7	30-276-037-11	Nut ...	2	
8	S590	Bolt (1 $\frac{3}{8}$ in. U.H.) ...	2	
9	41-148-203-10	Trip control ...	1	
10	H1702	Distance piece ...	2	T100S, T100C and
11	H1701	Sleeve nut ...	2	T100T
12	H1668	Bracket ...	1	
13	11104/04/2	Bolt ($\frac{1}{2}$ in. U.H.) ...	2	
14	S26-2	Spring washer ...	2	
15	D490	Speedometer cable (58 ins. long)	1	Smiths DF9110/00
16	E5755	TACHOMETER GEARBOX (Body E5757)	1	
17	E5153	Securing screw ...	1	
18	E5156	Bush ...	1	
19	E5155	Flanged bush ...	1	
20	E5157	Driving gear ...	1	
21	E5759	End cap ...	1	
22	E6300	"O" ring ...	1	
23	E5578	Driven gear ...	1	
24	E6122	Driven gear housing...	1	
25	E6299	"O" ring ...	1	T100R
26	E6124	Bush ...	1	
27	E3309	"O" ring ...	1	
28	E5881	Set screw ...	1	
29	D648	Tachometer cable (28 in. long)	1	
30	RSM3003/01	Tachometer ...	1	
31	31-371-398	Spade ...	1	
32	D494	Circlip ...	1	
33	E6961	Sealing washer ...	1	